

Protocol Coordination for Reliable Data Transfer and Error handling in Mobile Ad-hoc Networks

N. Satheesh Kumar *1 , # Dr. N, Sathyanarayana 2

*1 Research Scholar, Department of CSE, Rayalaseema University, Kurnool, AP, India.

2 Professor, Nagole Institute of Technology, Nagole, Hyderabad, Telangana, India.

ABSTRACT

Mobile Ad-hoc Networks have been increasing their popularity in recent years due to ease of deployment and low cost of its components. No infrastructure based network support is not required for MANETS because each node communicates with other nodes through the radio frequency. The routing protocols are challenged with establishing and maintaining multi-hop routes in the face of mobility, bandwidth and power constraints. The services provided by the current technologies for multimedia transaction is not sufficient in terms of quality of service and timely delivery of data. In this paper we tried to solve these type of problems by proposing reliable data transfer protocol, which is capable of delivering multicast and unicast data in mobile ad-hoc networks. The protocol has been designed to work on top of the IEEE 802.11 protocol without any modifications in the hardware structure.

Keywords: Bandwidth, RDT, Mobility, IEEE

I. INTRODUCTION

In Mobile Ad-hoc Networks, the routing protocols are challenged with establishing and maintaining multi-hop routes due to frequent mobility, bandwidth limitations and power constraints. The bandwidth may be reduced due to effects of multi-hop access, interference of signal and channel fading.

Let us assume the system architecture having set "S" of "n" mobile nodes which is capable of communicating through the wireless communication medium. i.e.

$$S = \{x_0, x_1, x_2 \dots x_{n-1}\}$$

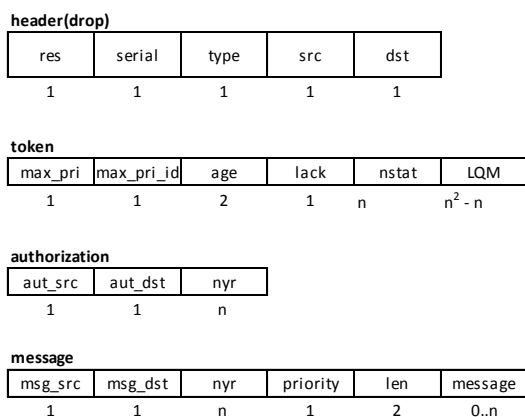

Figure 1. Frames of Protocol (in Bytes)

To exchange the messages between them, the nodes from the set will use a common shared communication channel. A subset of a node is defined as a collection of nodes which can hear the transmission of a particular node "x_i" and its neighbors. Each node will maintain its own reception and transmission priority queue. The priority may be from 0 to 127, where "0" is the lowest priority and 127 is highest priority level. Each message exchanged between nodes will be based on its priority. If any two messages having the same priority level, then the messages will be transmitted based on FIFO (First In First Out) order. When a message is transmitted by an application from one to another node, it will be placed in the transmission queue. The wireless reliable data transfer (RDT) protocol will insert the message into reception queue by taking it from transmission queue. Finally the application from the destination node it will pop the message. This protocol generally works in following three phases.

- i. Priority Phase(PP)
- ii. Authorization Phase(AP)
- iii. Transmission Phase(TP)

This protocol check for the highest priority messages at current situation in Priority phase. During this phase, to reach the node which is having highest priority message in the network at this situation, a token travels through all the nodes. The token holds the information like the level of priority for the corresponding message and its owner from the set of nodes. The node which initiates the priority phase indicates that the highest priority message in its own queue and the same will be updated in the token. After updating the token, it will be send to another node. The receiver node will check in its priority queue, whether any message having highest priority than the priority in the token which is transmitted by the sender, it updates the token information and continue the phase. The same process will continue until the token reaches to the last node, which knows the identity of the message which is having the highest priority and initiates the authorization process.

Subsequently an authorization to transmit is sent to the node which is having the highest priority in authorization phase. The node calculates the path to the node which is having highest priority message based on the topology information which is shared among the members of the network and sends the authorization message to the first ever node in the path, from then to second node in the corresponding path. Same will be continued until authorization reaches to the node with highest priority message. Then transmission phase was initiated.

In the transmission phase, the message will be transmitted to the destination node. The process is similar to the one in authorization phase. The node that has received the authorization calculates the path to reach the destination. It sends the message to the first ever node in the path then to second node and finally to the destination node. When transmission phase finished its operation then the node in the destination initiates the Priority phase again.

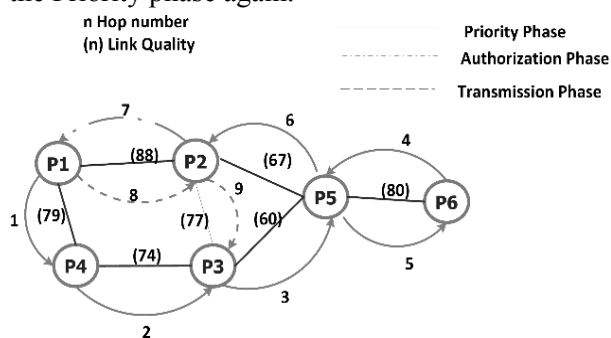

Link Quality matrix						
	P1	P2	P3	P4	P5	P6
P1	-	88	0	79	0	0
P2	88	-	77	0	67	0
P3	0	77	-	74	60	0
P4	79	0	74	-	0	0
P5	0	67	60	0	-	80
P6	0	0	0	0	80	-

Figure 2. A hypothetical situation described by the network graph and the corresponding LQM and the hops sequence of the protocol

II. LINK QUALITY MATRIX

The RDT protocol defines a network connectivity graph to describe the topology of the network. The network connectivity graph will contain positive values on the edges of the graph. These values are used to indicate radio signal and link quality between them. We can represent these values in the form of matrix to make link quality matrix. The values from the link quality matrix will represents the link quality between the nodes X_i and X_j . Each column in the link quality matrix will represent the links of node X_k with its neighbors. The signal strength may be different from transmission to its reverse transmission i.e. the signal received by X_i when X_j transmits may be different from the signal received by X_j when X_i transmits. Because of this, when it is computing the path, it will select the minimum value from the set of corresponding values.

$$lqm_{ij}(\min) = \min(lqm_{ij}, lqm_{ji})$$

The elements of the link quality matrix are functions of the radio signal links between nodes. To calculate them, we use the received signal strength indicator (RSSI) defined by the 802.11 protocol. The physical sublayer measures the energy observed at the antenna used to receive the current frame. The 802.11 devices provide this value to the device driver. Some card models provide information on noise as well. With these two parameters, we can estimate the signal to noise ratio(SNR) for every frame received and estimate link quality between nodes, representing it with values in the $[0, \max_lq]$ range. The calculation of the path in the authorization and transmission phases is based on these values. The Dijkstra algorithm for the single source shortest path problem for directed graphs with nonnegative edge weights is applied to the graph that

represents the matrix M , derived by means of a simple heuristic from the link quality matrix.

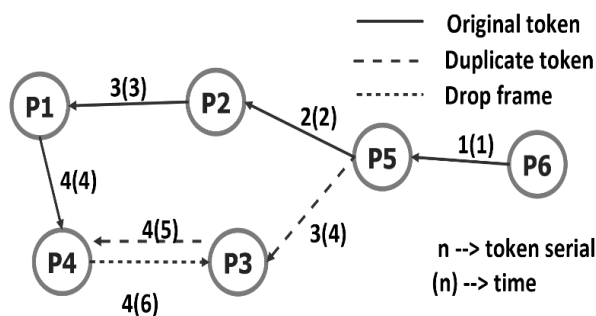

Figure 3. Token duplication resolution mechanism. In case of message or authorization duplication the mechanism works in similar way

III. DEFINING FRAMES

The frames may be divided into two parts called primary and secondary data as shown in fig 5.1. The primary data may be treated as header and which is common to all frames. The secondary data is different from one to others based on frame type. If we consider the frame format, the first byte with the field name "res" is reserved to establish the communication between the reliable data transmission (RDT) protocol and network interface card (NIC). The serial number of the frame will be holds by "serial" field and this field is used in mechanism to recover the errors along with the third field "retries" which is having the capacity 1 byte. The next field "type" represents the type of frame. The last two fields "src" and "dst" are used to represent the source and destination addresses of the frame. In general, the RDT address will be identified by the nodes through the range 0 to $n-1$. When a frame was transmitted by a node, it has to fill the source and destination addresses in the header with its RDT address and RDT destination address before broadcasting the frame. When a node broadcast the frame, all the neighbors can hear the frame due to shared radio signal but, only the destination node will process that frame.

The "token" frame adds the highest priority and its id in the first two fields with the size of 1 byte each. The third field "age" generally used to check and hold the oldest message in the message queue with the same priority level. To keep track of acknowledgements of frames which are transmitted in the last transaction, the "lack" field is used. The next field "nstat" represents the status like whether the frame was reached, not reached, lost or searched of a particular node. For

example, $nstat[i]$ used to represent the status of node p_i . The last field "LQM" in the token holds information of link quality matrix.

The authorization frame adds the address of source and destination of the authorization. It also adds the value of "nyr" variable with the field length of 1 byte, which also used to avoid the infinite loops in message delivery stage and at the authorization stage. The message frame adds the RDT address of the source and the destination. The "priority" field holds the priority of the message and "len" fields holds the amount of data carried and its priority by the particular frame. The "data" field used to represent the payload of the frame and finally the last field "drop" is a simple header and can be identified by "type" field.

IV. PROTOCOL PHASES

In this section we described the three phases of protocols in detail. we described the protocol phases with the assumption that the network is connected, all the nodes know the network topology.

A. Priority Phase

In this phase, when node X_k initiates the priority phase process, it creates a new token and copies it local LQM value in the respective field in the token, sets $nstat[i]$ to "unreached" and $nstat[k]$ will be set to "reached" initially. The value $nstat[k]$ is set to "reached" means except the node X_k , the token has not reached to any other nodes in the current situation.

For All i belongs to $[0, n-1]$; $i \neq k$.

Afterwards, the token checks the priority level of highest priority message in the transmission queue then appends the corresponding values in the fields "max_pri" and "max_pri-id". The "max_pri" fields holds the value and "max_pri-id" field holds the address of RDT. The "age" field represents the waiting time of a message in the queue, i.e. the time spent in milliseconds in the message queue up to that moment. By this way the node X_k becomes the highest priority message holder. Then it analyzes the link quality matrix to know which node is sharing the best quality link with it. Once the best quality link was obtained, sends the token to it. Let us assume the node X_{ij} receives the token, it sets the $nstat[ij]$ to reached and

update the link quality matrix token with its local data and saves the matrix locally. Once the matrix was saved, it increases the "age" field by a quantity equal to the duration of one token-pass hop. Then it looks for the highest priority field i.e. "max-pri" of the token and this value is compared with the priority value of the most highest priority message in its queue. If it finds any highest priority message from the queue, it updates "max-pri" and "max-pri-id" fields. If it holds a message with the same priority, it updates the token. Consequently, it will select the not yet reached node from the set of nodes with which it shares the best link quality, and sends the token to it. If a node only listens to the node from where it receives the token, it can return the token to the node from where it receives after updating. By this we can understand that a node can receive the token several times during the priority phase. If that is the case, it has right to update the "max-pri" and "max-pri-id" values. This scenario helps to reduce the well-known priority inversion problem. The same process is repeat until all the nodes have been reached by the token.

nstat[i]=reached forall i

The last node to receive the token knows the highest priority message holder identity, i.e. which contained the highest priority in its "max-pri-id" field and is responsible for sending the authorization to it.

B. Authorization Phase

The node which initiates authentication process will calculate a path to the destination node. To calculate the path, the node applies well known Dijkstra algorithm to a distance matrix derived from the link quality matrix. This algorithm returns a path to the destination as a set of nodes represented by $X = \{X_{x1}, X_{x2} \dots X_{xn}\}$. Then the node creates an authorization and update the "aut-src" and "aut-dest" fields with the highest priority message holder address and its own address respectively and start sending the authorization to the first node "X_{x1}" in the path. When "X_{x1}" receives the authorization, it looks at the field "aut-dest" and if it contains the address, it ends the authorization process otherwise, it calculates the following path

$$X^1 = \{X^1_{x1}, X^1_{x2} \dots X^1_{x(n-1)}\} \text{ Where } X^1_{xk} = X_{x(k+1)} \text{ } k < n$$

i.e. since the calculation is executed over the same link quality matrix, the path calculated will be the same except that the first hop has already taken place. The same topological information is available with each node and due to this, the bandwidth will be saved at the time of recalculation of the path in each hop. The node repeats the process, routing the message to the next member of the path, leaving the "aut-dest" field without any changes.

C. Transmission Phase

When the highest priority message holder receives the authorization to transmit, it takes the highest priority message out from its transmission queue and creates a new message frame and places the data in the "data" field. It fills the "msg-src" and "msg-dest" fields with its address along with the destination address and calculates the path to the destination. Then it fills the fields "priority" and "len" with the message priority and data length and sends it to the first node in the path. When later receives the message, it checks the field "msg-dest". If it contains the address of the destination, it appends the message into the queue of recipient and starts a new priority phase. Otherwise, it will continue with the path computation and repeats the process, the message is then routed to the next member which is available in the path and leaving the "msg-dest" field without any modifications.

V. ERROR HANDLING

For any protocol, we need to manage the possible reasons to get the errors. Similarly this protocol also have two possible reasons to get the error, they are either node failure or communication error. The node failure is occurred frequently in all the networks and the communication error will occur especially in wireless networks. This protocol was designed for error recovery not only in the case of real time behavior but also network topology in most of the cases when error occurs.

A. Node Failure

When a token is transmitting from source to destination with explicit acknowledgement, the receiver has to send an acknowledgement in the form of message to the sender. Let us assume after receiving the token by the receiver, it sends an acknowledgement to the sender node, but if the node has failed immediately after

transmitting the acknowledgement by the sender to receiver, the token is lost and it needs the regeneration of the token to retransmit. In RDT, when a node X_k sends a frame of any type to the node X_p , it listens to the channel for timeout. The receiver node X_p will process the frame received and sends it to the next immediate node X_q . The first sender listens to such a frame as well and interprets it as an acknowledgement. This technique permits saving of bandwidth and eliminates the need for monitor node. In any case, if the first sender does not hear the frame within the specified time or timeout, it supposes that the node X_p has failed or is out of its coverage area. In this case, the behavior depends on the phase that the protocol is in. If it is in the Authorization or transmission phase, the node X_k discards the frame and starts a new priority phase. If it is in the priority phase, the X_k sets the $nstat[p]$ field to "reached", and modifies the local link quality matrix, the link quality matrix carried by the token to exclude the node X_p from the set of its neighbors by setting $lqm_{kp} = 0$ and continues with the priority phase, sending the token to the another node. This solution excludes the node X_p in the current priority phase to preserve network temporization but not necessarily in the next priority phase. If the node X_p has not actually failed but let us assume, has moved away from the node X_k but not from another neighbor X_q , the latter will reinsert the node X_p in the next priority phase by simply passing it the token with any additional cost. If the node X_p really broken or has moved away from all other nodes, in the next priority phase all its neighbors will try to pass the token to it one after the another until the node X_p is isolated. When this occurs, the node that starts the next priority phase identify this node as *lost* setting $nstat[p] = lost + r$ where $0 \leq r < n$ and X_r does not belong to the set of nodes

B. Reinsertion of lost node:

The number ' r ' represents the identification of lost node to *search* in the current priority phase. If any node is reappeared, it is impossible predict the node location. Simultaneously, the nodes will be organized themselves those still belongs to the network to search for the lost node one after another in the successive priority phase. When the node X_r receives the token, it looks at the $nstat$ array. If one of the elements contains the value $lost + r$, it tries to send the token to X_p . If the later acknowledges the frame, it is reinserted in the

network with no additional cost. Otherwise, the node X_r sets $nstat[p] = searched + r$ and continues the priority phase. No other nodes try to search for that node in the current priority phase, since this would break the network temporization. The node that starts the next priority phase modifies the field $nstat[p] = lost + ((r + 1) \bmod n)$ if $X_{(r+1) \bmod n}$ node is not a lost node and continues the same phase. Like this all the nodes not lost will search for the lost node one after another in the successive priority phase of the node take place.

C. Frame Duplication

Let us consider the scenario where, in the priority phase, the node X_k sends a token to the node X_q and waits for an implicit acknowledgement. The node X_q processes the frame and sends the frame to the node X_r . As we discussed in the last section, the last pass is also the acknowledgement for the node X_k . If the node X_r hears the frame but X_k does not, a token duplication occurs. In fact, the node X_k marks the node as *reached* and continues the priority phase by sending the token to another node. The node X_r continues the priority phase as well and at that moment there are two token in the network. To solve this problem we introduced the *serial* field in the frames. This contains a value that is set to zero when the first priority phase begins. Before each transmission, the sender node increases this value, saves it locally, and then transmits. The node will discard the frame and informs the sender by sending *drop frame* when it receives a lower *serial* frame or equal to the *highest* serial that it has transmitted. In figure 5.3 an example situation is presented. The *authorization* or *message* duplication can occur in the same way. In keeping with the behavior, the unacknowledged node discards the *message* or *authorization* and creates the new *token* frame. The receiver of the authorization / message continues to route the frame along the path. At that moment there are two distinct type of frame travelling in the network. Just as in the case of simple token duplication, the first node that receives a frame with an old *serial* will discard it.

D. Frame Retransmission

It is possible to retransmit the frame in this protocol. When a node sends a frame but does not receive an implicit acknowledgement within timeout, it can

reattempt the transmission a fixed number of times. The use of this capacity can provoke in some situations, similar problems to frame duplication. Let us consider the scenario in which node X_k sends a frame to the node X_q and the latter to node X_r that will receive a duplicated frame that should not propagate. In this case the node X_q recognizes that it is the same frame looking at the *serial* and *retry* fields and send a *drop* frame back to the node X_k that is informed, in this way, that it must discard the frame. On the other side, this capability alerts the real time timing of the protocols and must be considered at the planning time since each transmission can entail n retransmissions.

VI. PERFORMANCE EVALUATION

To evaluate the performance of the protocol, we tested the various characteristics to check whether the protocol was implemented correctly or not.

A. Behavior

We considered various behavioral characters to measure the performance of the protocol. Among them the first was priority based message exchange mechanism. For this we considered the four node network with heavy traffic generated at every node. The nodes have a transmission priority queue of 20 messages and each message will have a priority between 0 and 31 randomly. In each node, the messages with high priority had shorter delays and the nodes those having low priority with longer delays. This observation is shown in figure 5.4.

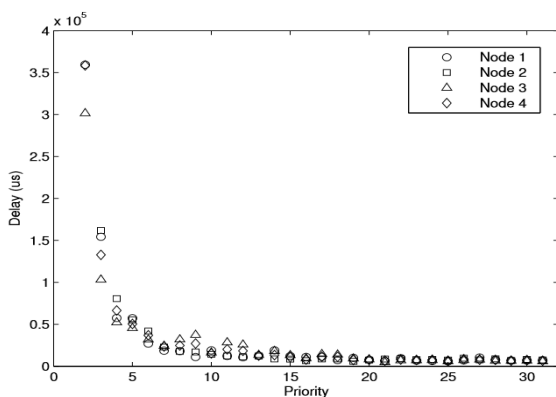

Figure 4. Priority behavior of the protocol

We conducted another experiment which concerns the fairness of the protocol. In this we considered the messages with equal priority at every node. The aim

was to verify that all the nodes had the same chances of sending their messages. i.e. all the messages experience the same delay between their entry in the queue and their exit. The figure 5.5 shows the results of this experiment and fulfils the requirement.

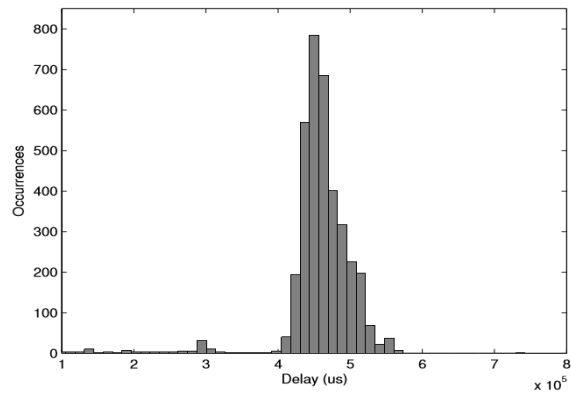

Figure 5. Fairness of the protocol

B. Throughput

We performed two experiments for reliable end to end throughput of the protocol. In both the cases the underlying 802.11 protocol network rate was 11Mbps. For the best case, we created a completely connected network of two, three and four nodes with high traffic at each node. In this situation the priority phase always lasted $n-1$ hops, the authorization phase have zero or one hop and the transmission phase lasted one hop. To determine the effective instantaneous bandwidth, we divided the payload of a message by the time lapse measured between the creation of new token and the delivery of the corresponding message.

To test the throughput in the worst case situation, the priority phase always lasted $2n-3$ hops, the authorization phase and the transmission phase lasted $n-1$ hops. We performed three tests with n equal to two, three and four nodes. We provided the nodes with fake LQM to simulate a chain of two, three and four nodes respectively and heavy traffic was generated in all the nodes. We calculated the effective instantaneous bandwidth just as we did in the best case but this time only taking into account the intervals in which the worst case situation occurred. The results are shown in the table 2.1 with the details of bandwidth and delay in milli-seconds.

Table 2.1. Reliable end to end data transfer with bandwidth (Mbps) and delay [ms]

VII. CONCLUSION

We introduced the features of RDT protocol, which can work over 802.11 based networks providing reliable data transfer support. It uses the token passing mechanism to provide guaranteed transmission times using the message priorities. This protocol deals with the frequent topology changes through the link quality matrix by sharing amongst the nodes. We also discussed the error recovery and management issues when multiple failures occurred during its transmission in mobile ad-hoc networks. The results are analyzed with 802.11 protocol in worst and best case situation.

VIII. REFERENCES

- [1]. Prashant Singh and D. K. Lobiyal, "DSR with link prediction using Pareto distribution IEEE International Conference on Networking and Information Technology, pp. 29–33, 2010.
- [2]. V. Ramasubramanian, Z.J. Haas, and E.G. Sirer, "SHARP: A Hybrid Adaptive Routing Protocol for Mobile Ad Hoc Networks," Proc. ACM International Symposium on Mobile Ad Hoc Networking and Computing (MobiHoc 2003), pp. 303-314, 2003.
- [3]. C.E. Perkins, P.R. Bhagwat, "Highly dynamic destination sequences distance vector routing (DSDV) for mobile computers", Proceedings of ACM SIGCOMM, pp. 234–244, 1994.
- [4]. D.B. Jonhson, D.A. Maltz, "Dynamic Source Routing in Adhoc wireless networks, Mobile Computing", T. Imie Linski and H. Korth, Eds. Kluwer Academic Publishers, Vol. 353, pp. 153–181, 1996.
- [5]. C.E. Perkins, E.M. Royer, S. Das, "Adhoc on Demand Distance Vector Routing", Proceedings of Second IEEE workshop on Mobile Computing Systems and applications, pp. 90–100, 1999.
- [6]. V. Park. S. Corson, "Temporally Ordered Routing Algorithm (TORA) version 1", IETF Internet Draft (draft-ietf-manet-tora-spec-04.txt), July 2001.
- [7]. L. Kleinrock, F. A. Tobagi, "Packet switching in radio channels: Part II-the hidden terminal problem in carrier sense multiple access and busy tone solution", IEEE Transaction Communications, Vol.23, no. 12, pp. 1417–1433, 23rd December 1975.

Size	2 Nodes		3 Nodes		4 Nodes	
	Best	Worst	Best	Worst	Best	Worst
100	0.284 [2.81]	0.258 [3.09]	0.262 [3.05]	0.177 [4.51]	0.247 [3.21]	0.110 [7.27]
256	0.893 [2.22]	0.830 [2.46]	0.573 [3.57]	0.387 [5.29]	1.478 [4.28]	0.249 [8.22]
512	1.62 [2.52]	1.47 [2.78]	1.05 [3.91]	0.658 [6.22]	0.875 [4.68]	0.422 [9.71]
1024	2.19 [3.74]	2.06 [3.97]	1.54 [5.31]	0.975 [8.41]	1.46 [5.61]	0.645 [12.7]
1500	2.33 [5.15]	2.28 [5.22]	2.27 [5.28]	1.26 [9.59]	1.79 [6.71]	0.813 [14.7]

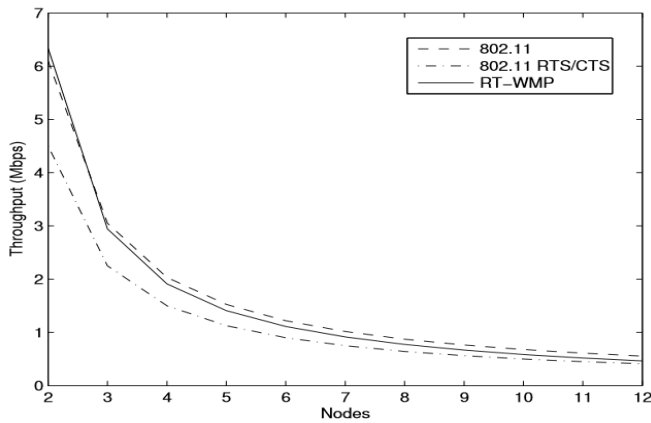

Figure 6. Comparison of RDT and 802.11 for the worst case situation

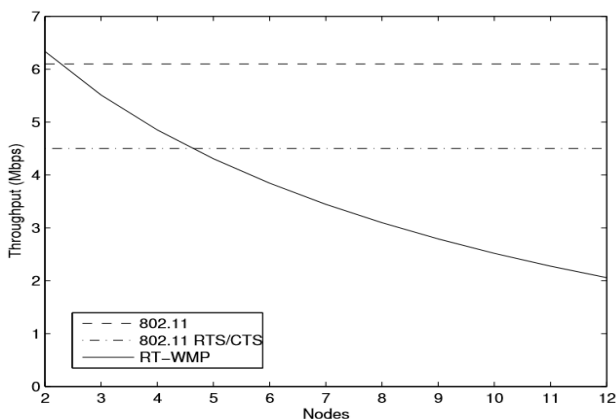

Figure 7. Comparison of RDT and 802.11 for the best case situation

- [8]. C. K. Toh, Adhoc Mobile Wireless Networks: Protocols and Systems, Prentice-Hall PTR, NJ, 2002.
- [9]. P. Karn, "MACA: a new channel access method for packet radio", Proceedings of the ARRL/CRRL Amateur Radio 9th Computer Networking Conference, September 22, 1990.
- [10]. V. Bhargavan, A. darnings, S. Shenker, L. Zhang, "MACAW - A Wireless Media Access protocol for Wireless Lans", Proceedings of ACM SIGCOMM, pp. 212–225,1994.
- [11]. C. Wu, V.O.K. Li, "Receiver-Initiated Busy-Tone Multiple Access in packet radio networks", Proceedings of the ACM SIGCOMM '87 Conference, pp. 336–342, 1987.
- [12]. Z.J. Haas, J. Deng, "Dual Busy tone Multiple Access (DBTMA) - a multiple access control scheme for adhoc networks", IEEE Transaction Communications, Vol. 50, no. 6, pp. 975–984, 2002.