

A Review: Noise System in MATLAB

Surbhi Sharma, Jitendra Raj Kumawat

Department of Computer Science and Engineering, Aryabhata College of Engineering and Research Centre, Ajmer, Rajasthan, India

ABSTRACT

Noise is an important factor that influences image quality, which is mainly produced in the processes of image acquirement and transmission. Noise reduction is necessary for us to do image processing and image interpretation to acquire useful information that we want. Because the working status of image transmitter is influenced by varied of factors, such as the environment of image acquired, different noises can be dealt with in different ways. Through the analysis of image spectrum, its difference can help us to choose different methods to do noise reduction while the information of the image is reduced to be the most. This paper illustrates some methods of noise reduction and takes one test image as an example. Since this image was affected by notable striping, the noise reduction methods of this stripped image are mainly studied. Grounded on the previous studies by some experts, we have applied some algorithms to this image. The Gray Value Substitution and Wavelet Transformation are satisfactory in stripped noise reduction. Then, MSR and PSNR are calculated to evaluate the processed image. Results suggest that the methods used in this paper are suitable in processing this noise.

Keywords: Noise; Image Processing; Frequency Spectrum; MSE; PSNR.

I. INTRODUCTION

Stripped noise is a usual phenomenon both in multi-sensor and sole sensor on the satellite and airplane platform. Because the working status of image transmitter is influenced by varied of factors, such as the environment of image acquired, different noise can happen in different ways. Striping is an important factor that influences image quality acquired by linear array CCD blocks. This may be more crucial for spectrometers because of the imperfect calibration of the detector characteristics and the necessity of higher CCD quality, which results in the most common striping^[1]. Noise reduction is an important and basic part in remote sense image processing. Not only spatial noise but also spectral noise may exist in the image because of the influence of natural light, surface topography, mixed pixel, etc. there are mainly two kinds of noise. One is plus noise and the other is multiply noise. Plus noise is usually caused by the noisy source and overlaid on the image to be shown:

$$y(u, v) = x(u, v) + n(u, v) \quad (1)$$

Where $x(u, v)$ = prior image
 $y(u, v)$ = the noisy image
 $n(u, v)$ = the noise

Multiply noise has the ability of modulability to the image, when the gray value changes little and noise is small, multiply noise can be taken as plus noise approximately.

$$y(u, v) = x(u, v) + x(u, v) n(u, v) \quad (2)$$

Noise is plus noise in most cases. Moreover, there are usually two ways to reduce the noises. One kind is space enhancement and the other is frequency enhancement.

Image frequency spectrum can express the characteristics of image noise. Through the analysis of image spectrum, its difference can help us to choose different methods to do noise reduction while the

information of the image is reduced to be the most. The spectrum has been done by Fourier Transformation to give a definite visual show.

This paper discusses the methods of noise reduction of this stripped image. Grounded on the previous studies by some experts, a test image is given and these methods are used to do stripped noise reduction. Then, we calculate the MSR and PSNR to evaluate the processes image. At the end of the paper, the comparisons of different noise reduction methods.

II. METHODS OF NOISE REDUCTION

Now, there are many methods to reduce noise. Traditional median filter and mean filter are reused to reduce salt-pepper noise and Gauss noise respectively. but when these two noises exist in the image at the same time, using only one filter method cannot achieve the wanted result. Suppose every sensor has the same balanced radiation distribution, the sub image histogram of every sensor is adjusted by histogram adjustment to one reference adjustment to realize noise reduction. The precondition of this method has much limit and not use when the involutes surface contains different objects. Besides, it is suitable in the image after not before the geometrical rectification. Principal component analysis (PCA) changes the noise PC image value to constant then the result image is got by inverse transformation. However, striped noise is difficult to reduce because the noise usually exists in the PC image, and the computation needs much time. Low pass filter in frequency domain is suitable to remove high frequency noise.

Moment matching is current usual method of noise reduction. Supposed that objects detected by each sensor have the same balanced radiation distribution, and the noted data change has linear relationship with plus and excursion of radiation distribution. Then stripped noise reduction can be achieved by adjusting mean stand deviation of each sensor to certain reference value. Moreover, this method can only be used in the image both after and before geometric rectification. This method is better than histogram adjustment. However, when small image or complicated objects can cause gray distribution asymmetrical, this method usually has “zonal effect”, which does not accord with distribution rule of natural geography element. Local disposal can be dealt with

processed image, but image distortion will not change. Fourier transformation gives thought of image frequency spectrum while wavelet analysis solves conflict of time and frequency resolution well when preserves advantage of Fourier transformation, so wavelet analysis has good localization characteristic in both frequency and spatial domain.

Traditional Fourier transformation sets high or low pass filter to reduce certain frequency signal, and then reduce stripped noise. This method is good in some condition, but when stripped noise mixed with the image physical texture in complicated object distribution surface, some image detail is also removed. The overall image is smoother while the image quality is decreasing. Wavelet decomposition has been widely used in image processing and analysis, which decomposes original image to approximate signal of different frequency ranges and detailed signal of multi-resolution layers^[2].

Different sensor will need different methods to remove their noises. There are two kinds of stripped noise in CHRIS/PROBA image: horizontal noise and vertical noise. Horizontal noise is some random loss of partial data in some lines of the images. Vertical noise or vertical striping is due to errors in the alignment of the sensors in the construction of the instrument (we can consider these errors as a constant). On the other hand, thermal fluctuations during the orbit causes small variations in the alignment of the optical elements, making that this vertical noise does not stay constant during all the time^[3]. References [3] and [4] give us some methods to remove these notable stripped noise. While in EROS image, uncalibrated sensors that introduce horizontal or vertical stripes across the image data sets occasionally degrade satellite data. A method based on one-dimension Discrete Fourier Transform is used to remove this kind of noise^[5]. MODIS image processing uses an improved moment matching method^[1] and interpolation method^[6]. Wavelet transformation is a common method to reduce noises. Usually, certain improved wavelet method will be used in different conditions^{[7][8]}.

Although different methods may lead to satisfactory results in different images, the basic step of noise reduction is that noise should be known before processing by some tools. Then we can find some

suitable methods so as to find best methods to acquire results we want.

III. TEST IMAGE AND ITS SPECTRUM

In this paper, we will introduce a test noise image to experiment some methods. The test image has a size of 512×512 which is seen in figure 1. In image processing, we use the software of MATLAB and Erdas 8.5 to do visual shows and comparison. The prior image is without noise which we do not show it here. Test image is contaminated by one kind of stripped noise, which is simulated.



Figure 1. Test image and its Fourier spectrum

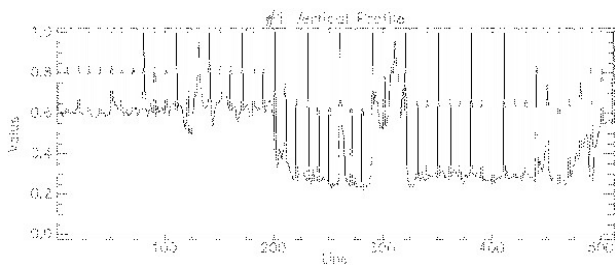

Figure 2. Vertical profile of test image

The gray value of this noise is high. Usually, the true value distribution of image is smooth, while the stripped noise changes in short periods. True value distribution in frequency domain is the low frequency part. Through the Fourier spectrum of this image, we can see that, noise in this image is symmetrical and locates in both high spectral domain and low spectral domain.

IV. IMAGE PROCESSING

4.1 Low pass filter

Noise is high frequency signal usually, so we can apply low pass filter to reduce it. The trapezium low pass filter (TLPF) we choose has certain

advantage of ideal low pass filter and filter that has smooth transition band, which has some ring ring. The pass function of TLPF is as follows:

$$H(u, v) = \begin{cases} 1 & D(u, v) < D_0 \\ [D_0 - D_1] / [D(u, v) - D_1] & D_0 \leq D(u, v) \leq D_1 \\ 0 & D(u, v) > D_1 \end{cases} \quad (3)$$

Where

D_0 = end frequency

= distance from one point to the origin

D_1 in plane

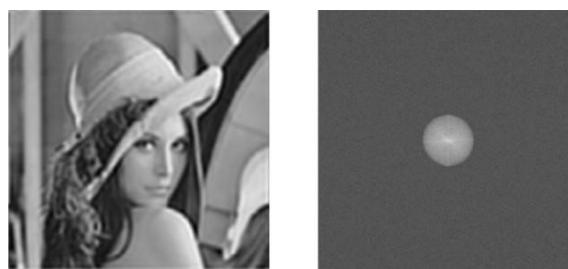

Figure 3. TLPF processed image and its Fourier spectrum

Figure 3 is processed image by trapezium low pass filter (TLPF). Results suggests: the noise will be removed when $D_1=50$. However, the ring is more serious when D_0 is bigger while the image is clearer. After processing, the image is blurred than that before processing.

Low pass filter can remove stripped noise well; however, much detailed information is also removed. So it is not fit to the hyper spectral image which needs much spectral information.

4.2 Gray Value Substitution

Because this noise is symmetrical and regular, we developed one simple method to reduce this stripped noise without Fourier transformation and wavelet transformation. This method firstly detects the noise value, then a value nearby is used to replace the noise value. After that, a median filter is used to do noise reduction further more. The result image can be seen in figure 3.



Figure 4 Image processing results of gray value substitution

We can see from this image, most noise line is modified and the line without noise is not affected by this method. So the image reserves much intrinsic information. However, some small stripes still exists, and the brightness after processing is larger than that before processing.

4.3 Wavelet transformation

Wavelet image denoising has been well acknowledged as an important method of image denoising. This method reserves most wavelet coefficient that contains information, so it can preserve image detail. Image denoising by wavelet usually mainly has three steps:

(1) Decomposition of image signal;

Choose appropriate wavelet and right decomposition level (note N), then N levels decomposition and computation to 2D image signal.

(2) Threshold quantification of high-frequency coefficient after level decomposition;

Choose an appropriate threshold to each decomposition level, and soft threshold quantification to high-frequency coefficient. The choose rule of threshold is equal to the prior part of signal processing.

(3) Image reconstruction using 2-D wavelet.

According to the Nth level approximation (low-frequency coefficient) and all the detail (high-frequency coefficient) after threshold

quantification, the wavelet of 2D signal is reconstructed.

In these three steps, the main part is threshold choose and threshold quantification.

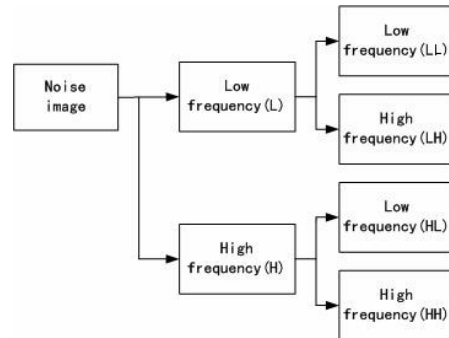

Figure 5. Wavelet decomposition flow chart

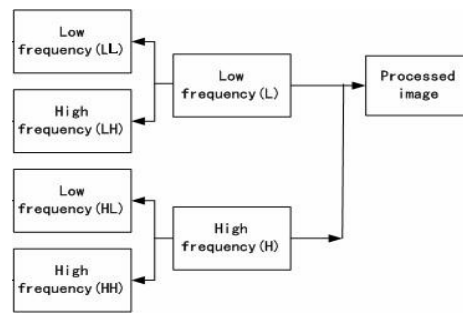

Figure 5. Wavelet reconstruction flow chart

Figure 4 and figure 5 show us the flow chart of wavelet decomposition and reconstruction. By use of MATLAB, the noisy image is decomposed. However, usual wavelet denoising cannot remove this stripped noise well (figure 6). Wavelet decomposition suggests, stripped noise still exists in the horizontal domain and the noise is not removed. However, the vertical and cross part of this image does not have much noise. So we can decompose this image and denoise the horizontal and approximate part, then synthesize the prior image after noise reduction.

In the flow chart, the part of LL and HL will be processed. Noise reduction of LL and HL can be low pass filter or other methods. Because the detail mainly contains in HH and LH, so the detailed information will be reserved much. The results is shown in figure 7.

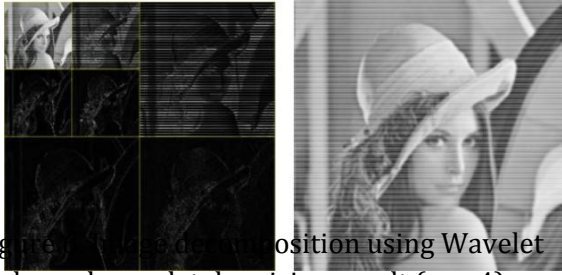

Figure 6. image processing result using Wavelet and usual wavelet denoising result (sym4)



Figure 7. image processing result by our methods

From the result, we can see that, the brightness of this processed image is reserved and the small stripes like figure 4 decreases. Using wavelet transformation of our method, the detail of this image can be reserved after noise reduction.

V. Results And Comparisons

From these three processed images, we can see that, wavelet transformation result has the best visual effect, then gray value substitution. Though low pass filter can remove noise very well, however, some useful information is also removed. In order to do a quality comparison, we calculated the mean value, standard deviation (std.dev), MSE and PSNR of different results, which is seen in table1.

$$mean = \frac{1}{M \times N} \sum_{j=0}^{M-1} \sum_{i=0}^{N-1} f(i,j) \quad (3)$$

$$std.dev = \frac{1}{M \times N} \sum_{j=0}^{M-1} \sum_{i=0}^{N-1} [mean - f(i,j)]^2 \quad (4)$$

$$MSE = \frac{1}{M \times N} \sum_{j=0}^{M-1} \sum_{i=0}^{N-1} [f(i,j) - g(i,j)]^2 \quad (5)$$

$$\frac{MSE}{255^2} \quad (6)$$

where $f(i,j)$ = prior image
 i, j = image coordinates

M, N = image size
 $g(i,j)$ = processed image

	MSE	PSNR
Noisy image		
Low pass filter	1260.8	17.12 42
Gray Value Substitution	28.014 0	33.65 71
Wavelet transformation	8.8177	38.67 73

Table1. Results and comparisons of MSE and PSNR

	Mean	Sta. dev
Prior image	124.0610	47.8240
Noisy image	153.7807	53.9107
Low pass filter	153.7810	25.8691
Gray Value Substitution	142.4265	44.0512
Wavelet transformation	142.4270	44.1347

Table 2. Results of mean and standard deviation value

From the test results and the result tables, we can see that, low pass filter is not fit in processing this stripped noise. And the other two methods is relatively suitable. Test result tables show that, standard deviation value of processed image by low pass filter has much difference with the prior image and noisy image, which suggests this method changes much image information, while standard deviation value of the other two methods changes little.

VI. REFERENCES

- [1]. LIU Zheng-jun, WANG Chang-yao, WANG Chen. Destriping Imaging Spectrometer Data by an Improved Moment Matching Method. JOURNAL OF REMOTE SENSING. 2015,6(4):279-284.
- [2]. Li Yinyan. 2014. Discussion on Noise Reduction in Image Processing.collegetimes.second part of August.
- [3]. Garcia J.C., Moreno J.. REMOVAL OF NOISES IN CHRIS/PROBA IMAGES: APPLICATION TO THE SPARC CAMPAIGN DATA, Proc. of the 2nd CHRIS/Proba Workshop, ESA/ESRIN,

- Frascati, Italy 28-30 April(ESA SP-578,July 2014)
- [4]. Dong Guang-xiang, Zhang Ji-xian, Liu Zheng-jun.2012. Remote sensing information. 6,pp.36-39.
 - [5]. Huang Ping S., Su Shun-Chi,and Tu Te-Ming. A Destriping and Enhancing Technique for EROS Remote Sensing Imagery. JOURNAL OF C.C.I.T., 2010, 32(2) :
 - [6]. Yang Jinhong, Gu Songshan, Cheng Minghu. 2007. Application of Interpolation Method Indestrpping MODIS Images. SCIENTIA METEOROLOGICA SINICA. 27(6), pp.605-609.
 - [7]. CHEN Jinsong, ZHU Yuqin, SHAOYun. 2003. Destriping Mult-sensor Imagery Based on Wavelet Transform. Remote sensing information. 2,pp. 6-9.
 - [8]. Chang Weiwei. 2007. Study on stripped noise reduction methods of hyperspectral imageD. Northwestern Polytechnical University.
 - [9]. Gonzalez Rafael C. 2003. Digital Image Processing (Second Edition). Publishing House of Electronics Industry.
 - [10]. FECIT Sci-Tech.2003. Wavelet Analysis Theory and MATLAB Application. Publishing House of Electronics Industry.
 - [11]. FECIT Sci-Tech.2005.Accessorial Image Processing with MATLAB 6.5. Publishing House of Electronics Industry.