

Usage of Face Recognition Method for Biometric Verification

Shivanand B Lamani¹, Ravikumar K², Arshi Jamal³

¹Computer Science Department Akkamahadevi Women's University, Vijayapur, India

²Computer Science Department GFGC, Gangavati, Karnataka, India

³Computer Science Department GFGC, Sindhanur, Karnataka, India

ABSTRACT

Authentication is a significant issue in system control in computer based communication. Human face recognition is an important branch of biometric verification and has been widely used in many applications, such as video monitor system, human-computer interaction, and door control system and network security. This paper describes a method for Student's Attendance System which will integrate with the face recognition technology using Personal Component Analysis (PCA) algorithm. The attendance will be marked based on facial recognition of the person. A group image of the class will be captured and detected faces are segmented from the captured image. The segmented faces are then compared with a predefined database of all the students of the class. A message will be sent to absentees through SMS using a GSM module. The system will record the attendance of the students in class room environment automatically and it will provide the facilities to the faculty to access the information of the students easily by maintaining a log for clock-in and clock-out time.

Keywords : PCA Algorithm, Face Reorganisation, Automatic Attendance, Authentication.

I. INTRODUCTION

Attendance is a vital aspect of administration which can often become a time consuming, repetitive job, lending itself to inaccuracies. Proposed method removes the need for manual paper registration and handwritten documentation, thus decreasing the administrative burden on faculties and allowing resources to be better spent elsewhere, ultimately leading to a more effective and productive operation. Proven to reduce absence, a student self-enrolment solution helps to monitor and improve student attendance. Absences are quickly identified resulting in appropriate action being taken swiftly and in the best interest of the student and the staff.

A biometric is a unique, measurable characteristic of a human being that can be used to automatically recognize an individual or verify an individual

identity. Biometrics can measure both physiological and behavioral characteristics.

Physiological biometrics (based on measurements and data derived from direct the human body) include:

- a. Finger-scan,
- b. Facial Recognition,
- c. Iris-scan,
- d. Retina-scan and
- e. Hand-scan.

Behavioural biometrics (based on measurements and data derived from an action) include:

- a. Voice-scan,
- b. Signature-scan and
- c. Keystroke-scan.

The face is an important part of who you are and how people identify you. For face recognition there are two types of comparisons. The first is verification and the second is identification.

- Verification is where the system compares the given individual with who that individual says they are and gives a yes or no decision.
- Identification is where the system compares the given individual to all the Other individuals in the database and gives a ranked list of matches.

In 1960s, the first semi-automated system for facial recognition to locate the features (such as eyes, ears, nose and mouth) on the photographs[2]. In 1970s, Goldstein and Harmon used 21 specific subjective markers such as hair color and lip thickness to automate the recognition. In 1988, Kirby and Sirovich used standard linear algebra technique, to the face recognition. All identification or authentication technologies operate using the following four stages:

- Capture: A physical sample is captured by the system during enrolment and also in Identification or Verification process.
- Extraction: unique data is extracted from the sample and a template is created.
- Comparison: the template is then compared with a new sample.
- Match/Non match: the system decides if the features extracted from the new sample.

The proposed method demonstrates how face recognition can be used for a successful attendance system to automatically record the presence of an enrolled individual within the respective venue. This system also maintains a log file to keep records of the entry of every individual with respect to a universal system time. A face recognition system is a computer application capable of identifying or verifying a person from a digital image or a video frame from a video source. One of the ways to do this is by

comparing selected facial features from the image and a face database.

This paper presents the design, implementation and experimental demonstrations of the attendance monitoring system. The contents are organized as follows. Section 2 introduces the concept of face reorganization. Section 3 shows the system specification and block schematic of attendance monitoring module. Hardware design is described in Section 4. The software design and algorithm is explained in Section 5. Test setup and testing procedure is interpreted in Section 6. Meanwhile results and analysis are shown in Section 7. Finally, Section 8 summarizes the research conclusions and sheds some light on the future work.

II. FACE REORGANIZATION USING PERSONAL COMPONENT ANALYSIS

In this paper we have reviewed a face recognition method based on feature extraction. By using extensive geometry, it is possible to find the contours of the eye, eyebrow, nose, mouth, and even the face itself. Principal component analysis for face recognition is based on the information theory approach. Here, the relevant information in a face image extracted and encoded as efficiently as possible[1][6].

In mathematical terms, the principal components of the distribution of faces or the eigenvectors of the covariance matrix of the set of face images, treating an image as a point (vector) in a very high dimensional face space is sought. Here principal component analysis method will be presented in more detail. The proposed system is based on an information theory approach that decomposes face images into a small set of characteristic feature images called Eigen faces, which are actually the principal components of the initial training set of face images. Recognition is performed by projecting a new image into the subspace spanned by the Eigen faces and then classifying the face by comparing its

position in the face space with the positions of the known individuals. The Eigen face approach gives us efficient way to find this lower dimensional space. Eigen faces are the Eigenvectors which are representative of each of the dimensions of this face space and they can be considered as various face features. Any face can be expressed as linear combinations of the singular vectors of the set of faces, and these singular vectors are eigenvectors of the covariance matrices[7].

III. SYSTEM SPECIFICATION AND BLOCK SCHEMATIC

3.1 Specifications

- Microcontrollers (AVR-ATMEGA 32), it is use for controlling the operation.
- LCD (16x2) display for message notification.
- GSM-900, use for sending SMS to persons.(operating frequency 900MHz for text sending.)
- USB(PL2303HX USB to RS232 TTL chip convertor) module use for serial communication.

3.2 Block Diagram

Figure 1 shows diagram of student attendance monitoring using face *recognition*. Microcontroller is interface with GSM board and LCD. Face of the particular student is captured by web-cam and stored into the database by using MATLAB code in the form of pixels. LCD are used for indicating students attendance. Different AT Commands are used for different purpose.

- Creation of database: The database is created, in prior to recognition process, which constitutes of images of all students of the class under different criterions like different facial elevations or positions and different lighting conditions.
- Capturing the image: The next step is to continuously capture the image of the students in the classroom in order to get adjusted to proper lighting conditions and elevations.

- Face Detection: The next part is face detection which determines the location and sizes of human faces in the captured image. The faces are detected from the captured image using Viola-Jones algorithm.
- Face Segmentation: The main objective here is to eliminate the foreign objects other than faces, which are detected [3]. The detected faces are segmented from the image and are pre-processed and stored for recognition [3][4]. The segmented image will be converted to gray scale for efficient recognition.
- Face Recognition: The face recognition is the most important part of this system. It is an automatic method of identifying or verifying a person from a digital image or a video frame. It is done by comparing the extracted features from the captured image with the images that are previously stored in the predefined database. The recognition process is implemented using PCA algorithm [5].
- Identification of absentees and sending a SMS: The absentees are those who are present in the data base but not in the captured image. An automatic SMS notification will be sent to the mobile numbers of the absentees.

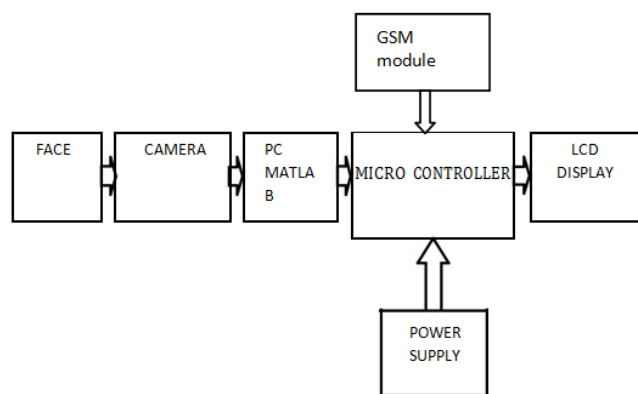

Figure 1. System Block Diagram

IV.HARDWARE DESIGN

Hardware design begins with selection of proper equipment required to do the various jobs. Selection is mainly on the basis of current and voltage ratings,

IC packages, clock rate and cost. Power supply is designed for the various components according to their ratings.

A. Camera: The camera used here is a PC web camera that captures the images of students for both database creation and test images.

B. AVR ATMEGA-32 Controller The high-performance, low-power Microchip 8-bit AVR RISC-based microcontroller combines 32KB ISP flash memory with read-while-write capabilities, 1KB EEPROM, 2KB SRAM, 54/69 general purpose I/O lines, 32 general purpose working registers, a JTAG interface for boundary-scan and on-chip debugging/programming, three flexible timer/counters with compare modes, internal and external interrupts, serial programmable USART, a universal serial interface (USI) with start condition detector, an 8-channel 10-bit A/D converter, programmable watchdog timer with internal oscillator, SPI serial port, and five software selectable power saving modes. The device operates between 1.8-5.5 volts.

C. Display Unit: The LCD is used as a display unit in the system to display the results. A 16x2 display and 4 data pins are being used. The operating voltage of LCD is 5V. A 16x2 LCD means it can display 16 characters per line and there are 2 such lines. In this LCD each character is displayed in 5x7 pixel matrix. This LCD has two registers, namely, Command and Data.

D. D.GSM Module: A GSM 900 module is a self-contained dual-band modem. This modem supports transmissions like data, fax, Short Messages (Point to point and cell broadcast) and voice calls. The total symbol rate for GSM at 1 bit per symbol in GMSK produces 270.833 K symbols/second. The gross transmission rate of a timeslot is 22.8 Kbps. GSM is a digital system with an over-the-air bit rate of 270 kbps. The main features of the modem are as follows:

- 2 watts E-GSM 900 radio section
- 1 Watt GSM1800 radio section.

- Echo Cancellation and noise reduction.
- Full GSM or GSM / GPRS software stack. It also comprises several interfaces like
- LED function indicating the operating status.
- External antenna (via SMA connector).
- RS232 Serial (via 9-pin SUB HD connector).
- Power supply (via 2.5mm DC power jack).
- SIM card holder.

E. Power supply design

An ideal regulated power supply is an electronic circuit designed to provide a predetermined voltage V_o , which is independent of load current, temperature and also of any variations in line voltage.

The power supply consists of:-

- Step-down transformer
- Bridge Rectifier
- Filter
- IC Regulator

Power supply is a vital part of all electronic systems. This circuit is required to drive the various components on the board. It is normal voltage regulator built with ubiquitous Transformer-Bridge Rectifier-Filter-Regulator assembly. We required a 5v supply for digital IC's.

A step down transformer in the block diagram decreases the value of primary mains voltage at 50 Hz and applies a pure sine wave with 0 average value to a rectifier circuit. The circuit converts such wave forms to a pulsating DC wave forms having a non-zero average or DC value. Such a ripple containing DC waveform is applied to a filter which reduces the ripple factor and improves the DC content in the waveform. If the output waveform across filter is directly connected to a load, without the regulator block, the load is said to be connected to an unregulated power supply.

V. SOFTWARE DESIGN

The name MATLAB is expanded as Matrix Laboratory. MATLAB is a high performance language for technical computing. It integrates computation, visualization, and programming

environment. It has sophisticated data structures, contains built-in editing and debugging tools, and supports object oriented programming. These factors make MATLAB an excellent tool for teaching and research. There are tool boxes in MATLAB for signal processing, image processing, symbolic computation, control theory, simulation, optimization, and several other applied sciences. The software part of this system is implemented using MATLAB version R2013a.

Algorithm:

1. Camera take the videos and taken out snapshot of videos
2. On snapshot images perform some operations like jpg to binary, binary to gray and gray to RGB.
3. This images compare with data base images. On the bases of different features.
4. If the data base image match to capture image then further operation will be done.
5. On the bases of match image whether the present and absent is counted.
6. If the student is absent then SMS will send to her/him parents/HOD/teacher.

VI. TEST SETUP AND TESTING PROCEDURE

Once the PCB along with the peripheral devices, it is necessary to verify that, the design is correct & the prototype is built to the design drawing. This verification of the design is done by writing several small programs, beginning with the most basic program & building on the demonstrated success of each. It is important to test and troubleshoot the hardware in the following steps:

1. Physically check all the connections.
2. Check whether power supply wires are firmly connected to all boards.
3. Check for any dry solders.
4. Check if IC's are physically in place.
5. Check whether all components are correctly mounted.

6. Check whether VCC and ground are shorted.
7. The PCB has a single main VCC and ground track on it.
8. Check IC's VCC and ground:
9. Once the above step is performed check individual IC's to see that correct pins are connected to VCC and Ground. This can be achieved by checking the voltage levels on multi-meter at each VCC and Ground pins of all IC's.

VII. RESULT AND ANALYSIS

- **Detection-** when the system is attached to a video surveillance system, the recognition software searches the field of view of a video camera for faces. If there is a face in the view, it is detected within a fraction of a second. A multi-scale algorithm is used to search for faces in low resolution. The system switches to a high-resolution search only after a head-like shape is detected.
- **Alignment-** Once a face is detected, the system determines the head's position, size and pose. A face needs to be turned at least 35 degrees toward the camera for the system to register it.
- **Normalization-**The image of the head is scaled and rotated so that it can be registered and mapped into an appropriate size and pose. Normalization is performed regardless of the head's location and distance from the camera. Light does not impact the normalization process.
- **Representation-**The system translates the facial data into a unique code. This coding process allows for easier comparison of the newly acquired facial data to stored facial data.
- **Matching-** The newly acquired facial data is compared to the stored data and (ideally) linked to at least one stored facial representation.
- The system maps the face and creates a face print, a unique numerical code for that face. Once the system has stored a faceprint, it can compare it to the thousands or millions of faceprint stored in a database.
- Each faceprint is stored as an 84-byte file.

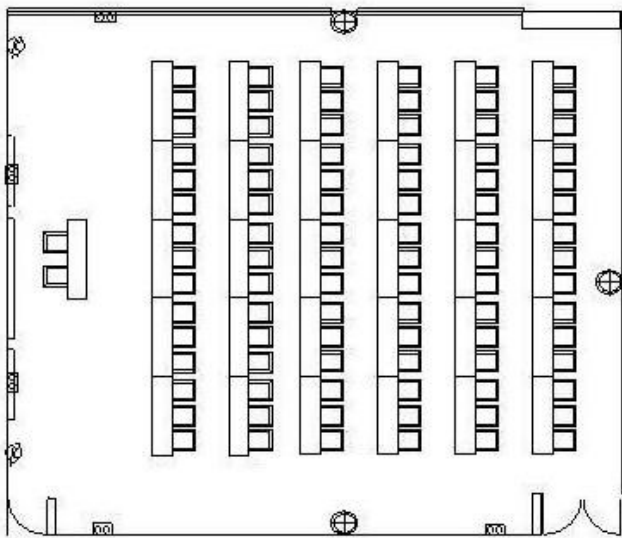

Figure 2. Structure of classroom

7.1 PERFORMANCE PARAMETERS:

A. False rejection rates (FRR) :

The probability that a system will fail to identify an enrollee. It is also called type 1 error rate.

$$FRR = NFR/NEIA \quad \text{---- (1)}$$

Where

FRR= false rejection rates

NFR= number of false rejection rates

NEIA= number of enrollee identification attempt

B. False acceptance rate (FAR):

The probability that a system will incorrectly identify an individual or will fail to reject an imposter. It is also called as type 2 error rate.

$$FAR = NFA/NIIA \quad \text{---- (2)}$$

Where

FAR= false acceptance rate

NFA= number of false acceptance

NIIA= number of imposter identification attempts

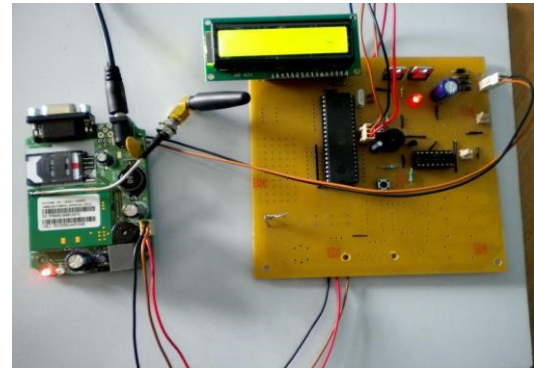

Figure 3. Prototype board showing GSM module and LCD display.

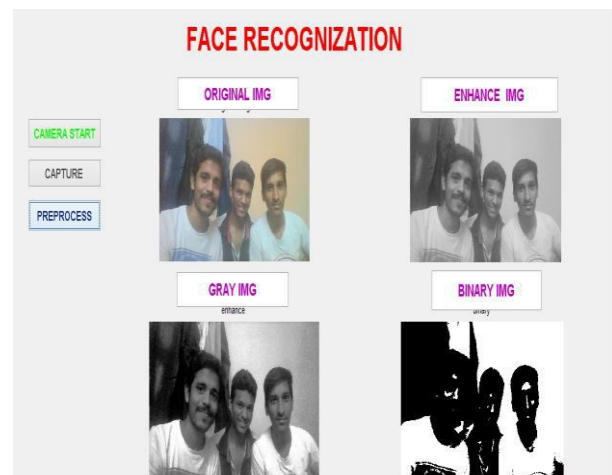

Figure 4. Result of face reorganization

VIII. CONCLUSION

Student attendance system using face recognition was designed and implemented. It was tested with different face image. This study represents a facial detection and recognition model with different windows working in parallel and independently. If face recognition is to compete as a viable biometric for authentication, then a further order of improvement in recognition rates is necessary. Under controlled condition, when lighting and pose can be restricted, this may be possible. It is more likely, that future improvements will rely on making better use of video technology and employing fully 3D face models. We hope that this system provides some additional insight into the field of face recognition and contributes to the development of the field. The MATLAB code was developed and it met the design criteria and solves the problem. Future work will be focused on verifying the algorithm performance

against general images and studying the required modifications to make the algorithm robust with any image.

IX. REFERENCES

- [1]. K.SenthamilSelvi, P.Chitrakala, A.AntonyJenitha, "Face recognition based Attendance marking system" IJCSMC, Vol. 3, Issue. 2, February 2014, pg.337 – 342
- [2]. Mr.C.S.Patil, Mr.R.R.Karhe, Mr.M.D.Jain, "Student Attendance Recording System Using Face Recognition with GSM Based" International Journal of Research in Advent Technology, Vol.2, No.8, August 2014 E-ISSN: 2321-9637
- [3]. Muhammad Fuzail, Hafiz Muhammad FahadNouman, Muhammad Omer Mushtaq, Binish Raza, AwaisTayyab, Muhammad WaqasTalib, "Face Detection System for Attendance of Class' Students" International journal of multidisciplinary sciences and engineering, vol. 5, no. 4, April 2014
- [4]. MathanaGopala Krishnan, Balaji, ShyamBabu, "Implementation of Automated Attendance System using Face Recognition" International Journal of Scientific & Engineering Research, Volume 6, Issue 3, March-2015
- [5]. S. B. Dabhade, Y. S. Rode, M. M. Kazi, R. R. Manza and K. V. Kale, "Face Recognition using Principle Component Analysis and Linear Discriminant Analysis Comparative Study" Responsibility of contents of the paper rest upon the author and not upon the publisher, Programme chair and AEMDS 2013
- [6]. M.A. Turk, A.P. Pentland. "Face Recognition Using Eigenfaces," IEEE Conference on Computer Vision and Pattern Recognition, pp.586--591, 1991.
- [7]. Li and S. Areibi, "A Hardware/Software Codesign Approach for Face Recognition," Proc. 16th International Conference on Microelectronics, Tunis, Tunisia, Dec 2004The word "data" is plural, not singular.
- [8]. AVR Atmega32 microcontroller www.atmel.com/images/doc2466.pdf.
- [9]. Nirmalya Kar, Mrinal Kanti Debbarma, Ashim Saha, and Dwijen Rudra Pal, "Study of Implementing Automated Attendance System Using Face Recognition Technique",International Journal of Computer and Communication Engineering, Vol. 1, No. 2, July 2012
- [10]. Vadiraj. M, Vinay Raghavendra. R, Prem Sagar. S, Vinod Kumar , "Face Recognition Based Attendance Monitoring System",International Journal of Emerging Research in Management &Technology ISSN: 2278-9359 (Volume-5, Issue-5)
- [11]. D. Nithya , "Automated Class Attendance System based on Face Recognition using PCA Algorithm" International Journal of Engineering Research & Technology (IJERT),ISSN: 2278-0181IJERTV4IS120249 ,Vol. 4 Issue 12, December-2015.