

Traffic Management System for Emergency Vehicles in City

Sachin Hirekar¹, Shubham Jagtap², Chetan Jangid³, Akshay Sawarkar⁴, Ajhar Shaikh⁵

^{1,2,3,4} Student, Department of Computer Engineering, Dr. D. Y. Patil School of Engineering, Lohegoan, Savitribai Phule Pune University, Pune, Maharashtra, India

⁵ Professor, Department of Computer Engineering, Dr. D. Y. Patil School of Engineering, Lohegoan, Savitribai Phule Pune University, Pune, Maharashtra, India

ABSTRACT

Lots of people loses their life due to ambulance unable to reach hospital due to unclearable road by traffic jams and number of these scenarios are getting increased day by day. In smart ambulance different sensors like heart rate sensor, temperature sensor will be judging status of patient values, the status of these health values will be send to hospital's database simultaneously traffic signals will be operated by using RFID technology. After getting status of patient values, hospital authorities will plan accordingly. As the smart ambulance will reach within range some meter, signal will be turned to green if it is red, the communication between smart ambulances will be done by Wi-Fi network through cloud.

Keywords: Smart traffic, smart ambulance, RFID reader, ESP8266.

I. INTRODUCTION

By considering the current heavy traffic conditions in India, in emergency situations like body part transplants, road accidents, etc. ambulance service gets highly affected. People die due to not getting proper and timely treatment which is a serious issue. In emergency situations time is a very important factor, so we have proposed a system to encounter this problem.

Our system i.e. 'smart traffic with ambulance', for ambulance gives a special path in which all the red signals will be turned to green for the ambulance which helps the ambulance in reaching its destination within time. Generally the ambulances pick up the patients and take him to the hospital, after reaching the hospital, the actual treatment starts. In this so much time is wasted and the patient might lose his life.

Our system continuously analyze vital health parameters of the patient like blood pressure, heart rate, body temperature in the ambulance itself and send it to the hospital's database while reaching the hospital, so the hospital authorities will know what Type of treatment to be given to the patient, saving so much time which ensures to save patient's life.

In this system, we are implementing smart ambulance system web Based Medical System. This system was implemented based on present criteria that tracking patient health records and another one is making traffic monitoring during the emergency ambulance using IoT. In this way it acts like a life saver project as it saves time during emergency.

II. LITERATURE SURVEY

In the era of smart cities, people face many problems regarding health issues like not getting aid on time or doesn't get quick facilities or delay in healthcare service. To overcome these situations, system describes a solution concept called 'Intelligent Ambulance with traffic control. This concept describes monitoring health parameters accessed by different sensors deployed on patient's body and transferring these to hospital system. At the same time traffic signal lights are monitored by driver of ambulance to reach to hospital as early as possible. RF communication is used for traffic controlling purpose. While designing algorithm to control traffic lights traffic density is also considered. [1]

Traffic is the biggest problem in India. It is very important to clear the traffic in case of any emergency. Vehicles are increasing day-by-day on a large scale in India that's why traffic problem is increased. Author used RFID tag which will be read by RFID reader for detecting a vehicle. With automatic traffic signal, traffic will be automated based on traffic volume. It will clear the path for emergency vehicles like ambulance, fire trucks etc. [2]

Currently we come to face a very common yet annoying issue in the world i.e. Traffic jams on the roads. Traffic jams during rush hours is very serious issue as emergencies like Police chases, Fire brigades or Ambulances may get stuck which might be life threatening. Here, a system is developed with the help of accelerometers, Zig-Bee, GPS and GSM modules to encounter the proposed problem. A system is developed with GSM and GPS system which detects the exact location of vehicles under emergency which is detected with the help of accelerometer to determine the state of the vehicle. This system is fully automated, so it was able to operate spontaneously right from detecting the vehicle under emergency to helping it to reach the hospital in time and safely. [3]

III. EXISTING SYSTEM

The current traffic control system in India are inefficient due to randomness in the traffic density pattern throughout the day. Traffic signal is unable to switch the signal light within a time as the interval time period is fixed. Due to this, the Emergency vehicles have to wait for a long time span. Sometimes it is completely controlled by traffic police which leads to traffic jams. Existing system is lengthy and time consuming. Once any hardware fail then all system fails. Traffic not clear during the ambulance coming because of traffic control not know where the ambulance is arrived.

Existing system does not check any patient health problem analysis during ambulance traveling. In this case the patient is analyse after reaching the hospital which risk the persons life.

IV. PROPOSED SYSTEM

The overcome the existing system problem we have implemented smart system. In proposed system we are making smart traffic signals which identify the emergency vehicles by reading the RFID tag placed on emergency vehicle, the tag will be read by RFID Reader which will be placed at certain distance from traffic signal according to traffic density in particular area. All the emergency vehicle containing RFID tag unique number and other vehicle details will be stored in the database, so that only emergency vehicle will be able to change the traffic signal by identifying its identity in database.

Our system also helps to analyse the patients health, we have used heart beat sensor to measure heart beat and temperature sensor to measure temperature which will be send to hospitals for pre-preparation.

Below diagram shows system architecture.

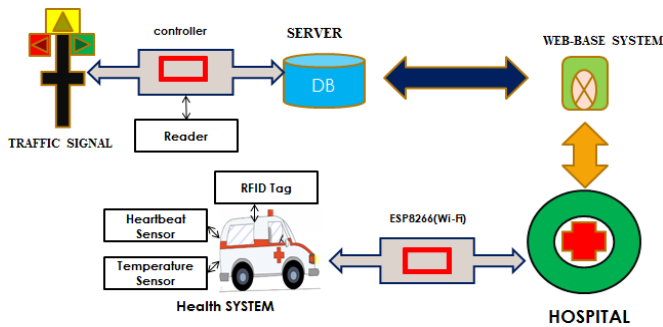

Fig 1. System Architecture

A. System Flow

This system consists of health analysis and traffic control system in an ambulance, signal, and a cloud server (Fig.1). The ambulance application is used for sending the patient health records based on the heartbeat sensor and temperature sensor during traveling one position to another and information continuously send to the cloud server. We designed the RFID based technology to detect the ambulance before traffic signal for clear the signal to fast reach at the hospital.

B. The general Ambulance Vehicle application

We developed this application as a Web application. After Admin authentication, it displays the patient health values from the ambulance vehicle, here admin check the patient heartbeat values, temperature values from the cloud server (Fig.1).

C. The cloud server application

After getting the request from ambulance vehicle using the ESP8266 for Wi-Fi network, it replies to the server patient records to hospital admin for analysis.

D. RFID Tag detection and Ambulance verification

RFID tag will be placed on top of the ambulance for convenient tag detection. Details of Ambulance (EMv) places with RFID tag will be stored in database so that

no other vehicle other than Ambulance (EMv) will not be able to change the Traffic signal.

E. Traffic Signal Control

Traffic signal will be placed with ArduinoUno which will be connected to database. So, when the RFID reader reads the tag the signal will be send from RFID reader to arduinoUno then the Arduino will check for ambulance details in database and when it matches the requirement the Arduino will change the signal

Hardware Component:

1. ESP8266



Fig 2. Wi-Fi model

Feature:

- Voltage:3.3V.
- Wi-Fi Direct (P2P), soft-AP.
- Current consumption: 10uA~170mA.
- Flash memory attachable: 16MB max (512K normal).
- Integrated TCP/IP protocol stack.
- Processor: Tensilica L106 32-bit.
- Processor speed: 80~160MHz.
- RAM: 32K + 80K. • GPIOs: 17 (multiplexed with other functions).
- Analog to Digital: 1 input with 1024 step resolution.

2. RFID Reader



Fig 3. EM-18 Reader

Feature:

- Voltage: 5VDC
- Current: <50mA
- Operating Frequency: 125Khz
- Read Distance: 10cm
- Size: 32mm(length) * 32mm(width) * 8mm(height)

3. RFID Tag



Fig 4. RFID card

Feature:

- Highly efficient
- Stringently tested for their quality
- Highly reliable

4. Heart beat Sensor



Fig 5. Heartbeat Sensor

Feature:

- Use IR LED and an optical transistor to detect pulsation in fingers
- Small and Compact module
- Easy to use.

5. Temperature Sensor



Fig 6. Temperature Sensor

The LM35 series are precision integrated-circuit temperature sensors, whose output voltage is linearly proportional to the Celsius (Centigrade) temperature. Since it has Linear + 10.0 mV/°C scale factor it is very easy to calculate temperature value.

V. MATHEMATICAL MODEL

System Description:

Input:

Function Health Calculation()

P : Patient

D : Doctor

S: Sensors(heartbeat, temperature)

M : Microcontroller

V : Value of Patient health

Output:

When Patient connect to the device in ambulance then automatically calculated patient health using the sensors and send to the hospital.

Input

Function Verification (id, request)

ID : unique id for ambulance.

Request : reader read ambulance id send to the server.

Output: Traffic signal automatically changes.

Success Conditions: Success when system sends correct patient value to the doctor and traffic monitoring automatically.

Failure Conditions: Our system fails when no records found from server for ambulance verification.

VI. CONCLUSION

This work is developed with a main intension of saving the life of a person. The traffic is cleared for fast running of the emergency vehicles. And at the same time, the patient's condition inside the ambulance is monitored frequently and the information is updated to the hospital server, which could be viewed by the doctor at the hospital and make the necessary arrangements.

VII. FUTURE SCOPE

The system is more manual than automatic. In the future scope, this system could be made completely automated as it could automatically set the change in traffic signal by knowing the path followed by the ambulance and system will share the updated information to the traffic police device which are in the path of ambulance. This saves more time and the patient is taken to the hospital in minimum time possible.

Also by putting RFID tags in all vehicles we can also make a system which can identify the stolen vehicle as the RFID tag has unique number so when the stolen vehicle passed by the traffic signal the RFID reader will read the signal and informs the last identified area of the stolen vehicle.

VIII. REFERENCES

- [1]. G. Beri, P. Ganjare, A. Gate, A. Channawar, Vijay Gaikwad, "Intelligent Ambulance with Traffic Control", in International Jour. of Elect, Electronics and Comp Systems, vol. 4 , pp 43-46, Feb. 2016.
- [2]. R. Sundar, S. Hebbar, and V. Golla, "Implementing Intelligent Traffic Control System for Congestion Control, Ambulance Clearance, and Stolen Vehicle Detection", in IEEE SENSORS JOURNAL, vol. 15, pp 1109-1113, Feb. 2015.
- [3]. W. Kang, G. Xiong, Y. Lv, X. Dong, F. Zhu, Q. Kong, "Traffic Signal Coordination for Emergency Veh.", in IEEE 17th International Conference on Intelligent Transportation System (ITSC), pp 157-161, 2014.
- [4]. Joshua, S. Rao, N. Rao. "An Intelligent Ambulance Traffic Signal Control System" in International Jour of Engg. and Computing, ISSN-2321 -3361, pp 10131018, Dec. 2014
- [5]. T. Mickus, P. Mitchell, T. Clarke, "The Emergence MAC (E-MAC) protocol for wireless sensor networks", in Engg. Applications of Artificial Intelligence, vol. 62, pp. 17-25, 2017.
- [6]. M. A. Kumar, G. A. Kumar and S.M. Shyni, Advanced Traffic Light Control System Using Barrier Gate and GSM, In the proceedings of 2016 International Conference, Computation of Power, Energy Information and Communication (ICCPEIC), 2016.
- [7]. SK Riyazhussain, Riyazhussain, C.R.S. Lokesh, P.Vamsikrishna and G Rohan, Raspberry Pi Controlled Traffic Density Monitoring System, In proceedings of 2016 International Conference, Wireless Communications, Signal Processing and Networking (WiSPNET), 2016.
- [8]. P Maheshwari, D Suneja, P Singh and Y Mutneja, Smart traffic optimization using image processing, in proceedings of 2015 IEEE

- 3rd International Conference, MOOCs, Innovation and Technology in Education (MITE), 2015].
- [9]. L Bhaskar, A Sahai, D Sinha, G Varshney and T Jain, Intelligent Traffic Light Controller Using Inductive Loops for Vehicle Detection, in proceeding of 2015 1st International Conference, Next Generation Computing Technologies (NGCT), 2015.
- [10]. E Shaghghi, A Jalooli and R Aboki, Intelligent traffic signal control for urban central using Vehicular Ad-Hoc Network , in proceedings of 2014 IEEE Asia Pacific Conference, Wireless and Mobile, 2014.

Cite this article as :

Sachin Hirekar, Shubham Jagtap, Chetan Jangid, Akshay Sawarkar, Ajhar Shaikh, "Traffic Management System for Emergency Vehicles in City", International Journal of Scientific Research in Computer Science, Engineering and Information Technology (IJSRCSEIT), ISSN : 2456-3307, Volume 4 Issue 8, pp. 144-149, September-October 2019.

Journal URL : <http://ijsrcseit.com/CSEIT194833>