

A Review on IoT Based Approach for Fire Monitoring System

Vaishno Tarhate¹, Ganga Prasad¹, Aman Parate¹, Prof. Ashwin Shinde²

¹BE Scholar, Department of Computer Science and Engineering, Dr. Babasaheb Ambedkar College of Engineering and Research, Nagpur, Maharashtra, India

²Assistant Professor, Department of Computer Science and Engineering, Dr. Babasaheb Ambedkar College of Engineering and Research, Nagpur, Maharashtra, India

ABSTRACT

A IoT Based Fire Warning System utilizing Arduino Uno R3, which is temperate and reasonable by all. This framework recognizes fire amid the presence of smoke or fire at a specific level and alerts the owner of the the property effectively and rapidly by utilizing Wi-Fi Module. AT Mega micro controller of Arduino controls every one of these exercises like flame sensor, smoke sensor and Wi-Fi module. This framework would help everyone and it is affordable by all to have one at their home and it likewise alert from the human misfortune and harm, which may occur because of fire.

Keywords : A Novel IOT Based Approach for Fire Warning System, Fire Detection, AT Mega, Arduino

I. INTRODUCTION

Fire risks can be exceptionally hazardous and cause human misfortune. The main answer for moderate these misfortunes is reacting to such a crisis circumstance rapidly. In developed nations like USA, Singapore and so on, it is government guideline to introduce a fire caution in all homes towards alarming property holder and Fire administration workforce in time for activity. Such sort of Fire Alarm framework doesn't exist in creating nations like India which result in a parcel of misfortunes and harm.

In such circumstances, distinguishing the fire well ahead of time and cautioning would diminish misfortunes of property and life. A fire or smoke alert framework can be observed locally or remotely as suitable. Remote caution framework gives the advantage of observing the reason from a far off area and making quick move dependent on message got dissimilar to manual framework. These Remote checking frameworks can be created in different ways

utilizing advances like remote sensor systems, Ethernet, picture handling and other computerized correspondence innovations. Fact that these frameworks are dependable and have the parcel of focal points, there are still bunches of concern being perplexing, in the compact, non-independent, costly and having excess appurtenances. So there is necessity for building up a framework that is dependable and responsive just as basic, effectively implementable and financially savvy from the point of view of the family unit in creating nations.

Fire risks cause miserable occurrences throughout the world, particularly in creating nations where the fire-well being measures are unstable and regularly lacking.

Fact that various propelled frameworks are utilized in common sense situations, a dependable, simple implementable and cost-effective robotized fire-caution framework isn't accessible. The current fire alert framework in the market these days is excessively mind-boggling in term of its plan and structure. Since

the framework is excessively perplexing, it needs customary preventive support to be completed to guarantee that the framework works well. Then, when the support is being done to the current framework, it could raise the expense of utilizing the framework. Accordingly, the created FAS are planned with a minimal effort micro-controller and every single dimension client can have one for a well-being reason. So there comes the requirement for an independent and self-sufficient fire recognition framework which could rapidly recognize the fire, raise an alert and furthermore now and again start fire smothering as well.

The frameworks outfitted with LM393 Flame sensor that can recognize horrible inadvertent circumstances, as it occurs, and with the assistance of a preparing unit can alarm in a few second by means of WiFi and signal for undertaking careful measures at the premises.

II. LITERATURE REVIEW

In this segment, survey on fire discovery advancements and counteractive action framework been examined. The vast majority of the fire discovery advances are arranged into two gatherings, which are Vision based, and Sensor based. These are altogether talked about in detail in this segment

A. IoT Based Smart Fire Emergency Response System (2018)

The Flame Sensor detect the fire and it activate the GPS which find the current location of the fire accident area. The location is stored in the cloud and activating message is send to the GSM module.

B. An IoT Based Fire Alarm and Monitoring System (Sep-2017)

In that the Galileo board unit responds to the instruction sent by the sensors. The objective of the application to manage the hardware devices remotely was also achieved. The successful in developing a programmable Galileo board based system with smart sensor and working actuator.

C. An IoT Based Fire Alarm and Authentication System For Workhouse using Raspberry Pi3 (Feb-2017)

In that Author tried to improve the problem of fire detection by using camera and image processing instead the sensors. Study presents the prototype system and implemented it after suggesting some type of fire detection algorithm.

D. Decision and Development of Automatic Fire Detection using SMS and Voice alert System (May-2016)

It give the alert the distant property owner efficiently and quickly by sending SMS via GSM network and voice alerting system. This system guides the usage of fire Extinguisher During the fire accident.

E. Development of Fire Alarm System Using Raspberry pi and Arduino Uno (2003)

Author tried to improve the problems of fire detection by using camera and image processing instead of sensors. Study presents the prototype system and implemented it after suggesting some type of fire detection algorithm.

III. SYSTEM IMPLEMENTATION

Processing Unit

Lolin new Node Mcu V3 is a microcontroller board providing a platform for controlling the signal/input from various sensors and other modules. It provides an

open source platform independent IDE that allows the programmer to process the electronic signals from attached components and control them. One of the most popular Arduino is Arduino Uno which is an 8 bit Atmel AVR Microcontroller with a clock speed of 16 MHz. Last but not the least, these boards are not expensive and have a very active developer's community. These are shown in Figure 3.1

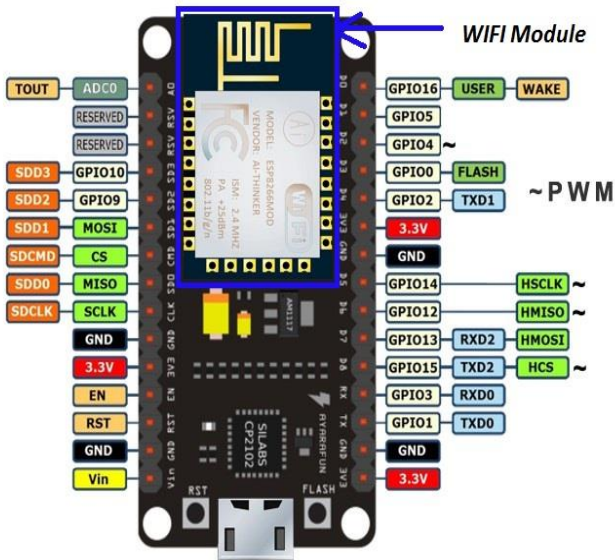

Figure 3.1 Physical outlook of Lolin new NodeMCU V3

Wi-Fi Module

Lolin new NodeMCU V3 contain WiFi Module And Arduino Kit. It contains both feature in single device. From which WiFi Module is used to connect with the server It provide notification to the owner and fire department.

Flame Sensor

In this sensor, the output voltage is linearly proportional to temperature measured in centigrade. The output of LM393 sensor produces an analog voltage as shown in Figure 3.3. LM393 sensor module increases the output by 10 mV/°C. So once the temperature goes beyond the pre-set temperature (50°C), the module will produce a high output. Now

towards detecting fire, flame sensor module been used which is highly sensitive to fire and flame spectrum. The module here detects the light wavelength between 760-1100 nm which is range of IR light. However the detection range is normally 3 feet and detection angle is 60 which are not that large to monitor a single room.

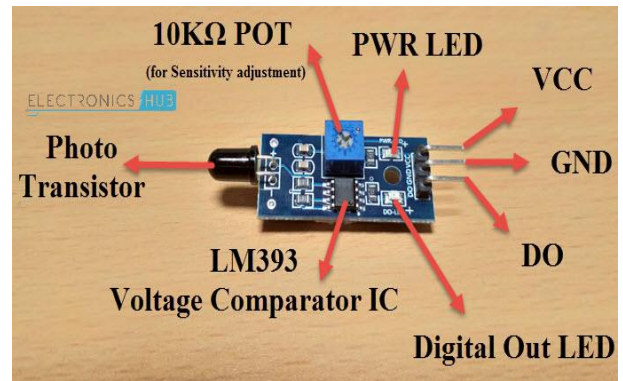

Figure 3.2 Structure of LM393 Flame Sensor

LM393 is an electrical sensor which is used to measure temperature of its surrounding. It's output is generated in the form of Electrical signal and this electrical signal is proportional to the input temperature, which it detects. LM393 is much more sensitive than other temp measuring devices (not accurate) and that's why it is most widely used temp detection device now-a-days. The internal circuitry of this IC is sealed and the external conditions will have no effect on the operation of LM393 and also its output is not affected under any conditions. LM393 is a 3 pin IC and it is used for temperature detection. The physical appearance of LM393 is shown in the image shown above in Figure 3.2

IV. CONCLUSION

The built up the fire alert framework is straightforward however it truly offers an immense division of App in habitation and furthermore producing fundamental well-being, explicitly in making countries around the globe. Utilizing this strategy, quick and furthermore legitimate

admonitions can be performed for us to trigger protection strategies to keep away from the hazard related with fire threats and furthermore diminish misfortunes related with life and furthermore property. This is the ready system more affordable fires that perform constantly to ensure fire prosperity way and can be presented in homes, organizations, practices, home articles, etc successfully. Gigantic business or perhaps non-business district can be regulated all through the prescribed framework introducing a few modules, every one of them for one story or possibly for the unit. At long last, the target of the venture was effectively accomplished with the correct and wanted outcomes. Thus this framework gives a superior and solid method for checking, controlling, finding and detailing of a spot enduring an on slough breakout.

V. REFERENCES

- [1]. N. Johnsaída, L. Rahul, T. Shalini Work On “IOT Based Smart Fire Emergency Response System” Published in International Journal of Advanced Research And Development (2018)
- [2]. Saumya Tiwari, Shuvabrata Bandopadhyay Work On “Iot Based Fire Alarm And Monitoring System” Published In International Journal of Innovation & Advance in Computer Science (Sep- 2017)
- [3]. Ahmed Imteaj, Tanveer Rahman, Mahammad Kamrul Hossain ,Mahammad Shamsul Alarm, Saad Ahamad Rahat Work In “An IoT based Fire Alarming & Authentication System for Workhouse using Rasberry Pi3”, Publish On International Conference on Electrical Computer and Communication Engineering (Feb-2017)
- [4]. R. Satishkumar, M. VinothKumar, D. Varatharaj, S. Rajesh, S. Gowthaman Work on “Design & Development Of Automatic Fire Detection Using SMS & Voice Alert System” Published In International Journal of Scientific & Research (May-2016)
- [5]. Md. Saifudaullah Bin Bahriddin, Rosni Abu Kassim Work on “Develoment of Fire Alarm System using Raspberry Pi and Arduino Uno” Published In International Conference on Electronics and System Engineering (2003)

Cite this article as :

Vaishno Tarhate, Ganga Prasad, Aman Parate, Prof. Ashwin Shinde, "A Review on IoT Based Approach for Fire Monitoring System", International Journal of Scientific Research in Computer Science, Engineering and Information Technology (IJSRCSEIT), ISSN : 2456-3307, Volume 6 Issue 2, pp. 135-138, March-April 2020.

Journal URL : <http://ijsrcseit.com/CSEIT206246>