

# Online Question Paper and Question Bank Generator and Student Portal

Mudappala Pranav Nair<sup>1</sup>, Justin Paul<sup>1</sup>, Arun Babu<sup>1</sup>, Prof. Manoj Singh<sup>2</sup>

<sup>1</sup>Department of Computer Science, SIES College of Arts, Science and Commerce (Autonomous), Sion (W), Mumbai, Maharashtra, India

<sup>2</sup>Head of the Department, Department of Computer Science, SIES College of Arts, Science and Commerce (Autonomous), Sion (W), Mumbai, Maharashtra, India

## ABSTRACT

Examination process is an important activity for educational institutions to assess student performance. Thus the nature of the exam questions would determine the quality of the students produced by the institutions. Preparing the exam questions is very challenging, tedious and time consuming for the instructors. Thus with the help of this paper we present the solution in form of Online Question Paper and Question Bank Generator and Student Portal which makes use of Randomization technique. The design process performs the scrutiny and composes the examination paper using an efficient algorithm with a high rate of success. With this algorithm, the faculty needs to specify the subject, the question type and the difficulty level. From the entered input, the examination paper and question bank will be generated automatically. The editing of questions is performed using question edit options and the final paper/question bank will be stored as “.pdf” file formats and sent to the examination team for exam purposes. Students can also access the system for competitive examination purposes. The system shows characteristics like simple operation, a great interface, good usability, immense security, and high stability, reliability and easy to use.

**Keywords :** Question Paper, Question Bank, Examination, Student

## I. INTRODUCTION

Implementation is the process of converting a new or a revised system design into an operational one. The objective is to put the new or revised system that has been tested into operation while holding costs, risks, and personal irritation minimal. A critical aspect of the implementation process is to ensure that there will be no disrupting the functioning of the organization. Another factor to be considered in the implementation phase is the acquisition of the hardware and software. Once the software is developed for the system and testing is carried out, it is then the process of making the newly designed system fully operational and

consistent in performance. Implementation is the most crucial stage in achieving a successful system.

## II. SYSTEM MODEL

**Admin:** The Admin is able to login, add faculties, subjects, appoint Heads of the Departments and monitor all the transactions through the system. Reports are also generated through the system.

**Head of The Department:** The Head of the departments can add/update/delete courses, subjects, unit numbers, assign subjects to faculties according to the academic year.

Faculties: The faculties, including the head of the department can add questions according to the subject assigned to them and based on the question types they can generate various types and patterns of question papers/question banks like MCQ based, Subjective question based, Mixed etc.

Exam Committee: The question papers confirmed by the heads of the department will be sent digitally to the exam committee for examination purposes.

Student: A student can register himself/herself, choose a plan and opt for competitive exams preparation. The questions will be in the system, entered by the concerned faculty/tutor.

### Use Case Diagram

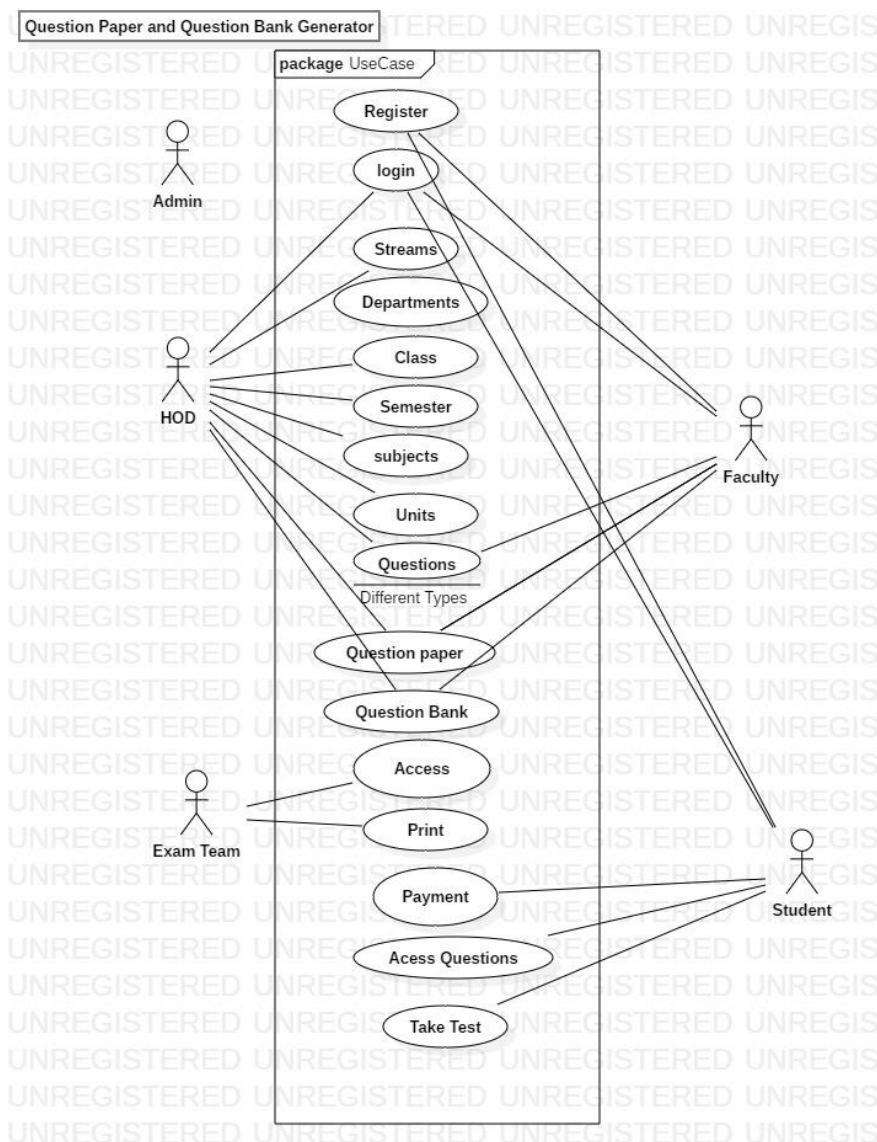

**ER Diagram**

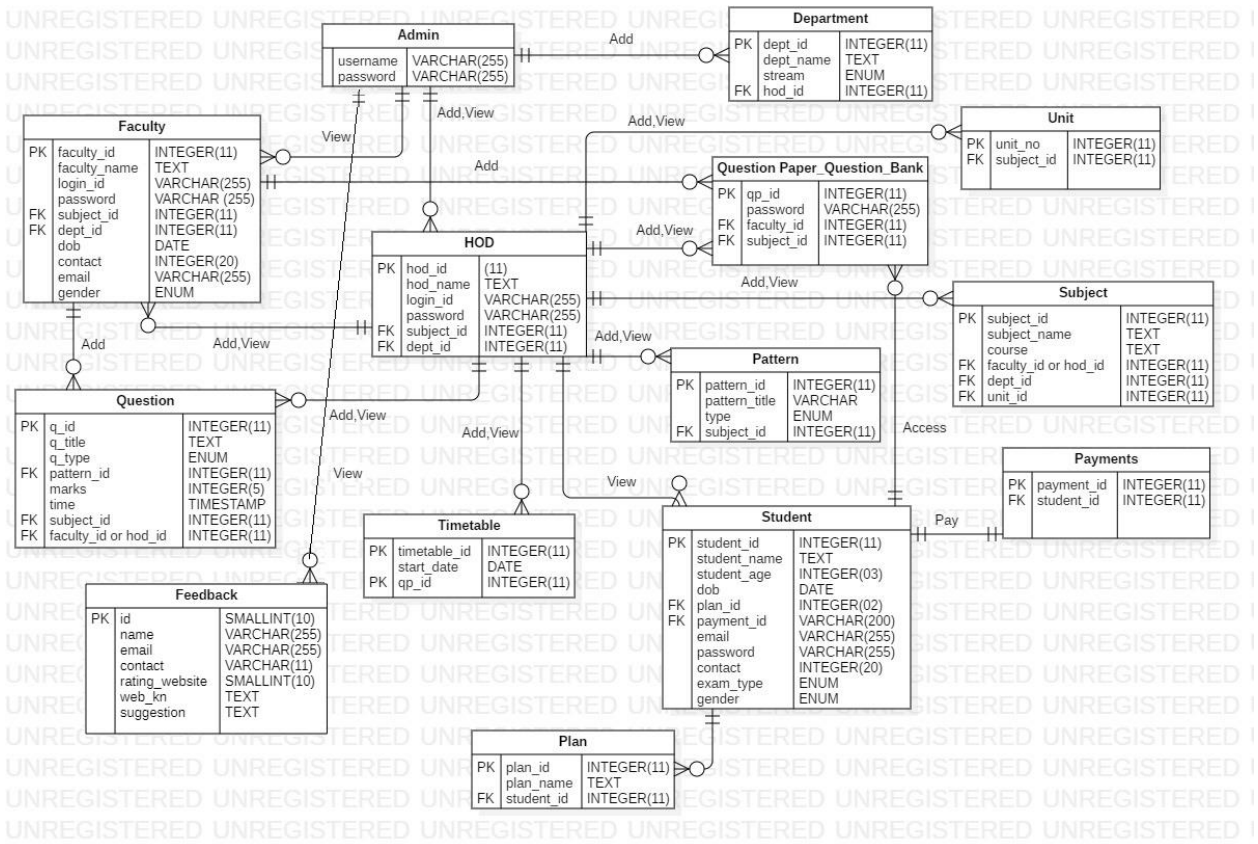

**III. FUTURE SCOPES**

The system can be expanded to a much higher level of controlling branches of various institutions and competitive examinations. Bodies like CBSE, State Boards can use the system as a centralized system to control the examinations and reduce the use of resources.

**IV. CONCLUSION**

Examination system is the pivotal point around which the whole system of education is based. Examination system comprises of number of laborious and error prone tasks, needing immense resources and time. Numerous electronic examination systems have been designed with the intent of improving the efficiency of current examination system. However, the existing e-examination systems are usually designed with little

consideration for security and legal compliance. Providing adequate security services are desired in e-examination system, especially in those examinations which evaluate students for grading. In this paper, we explore the use of security protocols for exchanging question paper and question banks in a much simpler and effective manner.

Also this portal helps the students study for various competitive exams without much of stress and anxiety

**V. REFERENCES**

[1]. Vijayalakshmi B.T, Bhavya B M, "Automatic Question Paper Generation System", International Journal of Scientific Research in Computer Science, Engineering and Information Technology (IJSRCSEIT), ISSN : 2456-3307, Volume 2, Issue 3, pp.767-771, May-June-2017.

- [2]. Subhash Rathod, Yogesh Bhaturkar, Kiran Bolange, Nitesh Sapkal, "Randomly generate question paper ", *International Journal of Scientific Research in Computer Science, Engineering and Information Technology (IJSRCSEIT)*, ISSN : 2456-3307, Volume 3, Issue 5, pp.618-623, May-June-2018.
- [3]. Suraj Gaikwad, Pooja Kamble, Pooja Borade, Suchitra Jadhav, Atul H. Shintre, "A Review on Mobile Oxford Application (MOBSFORD) (An android based mobile application)", *International Journal of Scientific Research in Computer Science, Engineering and Information Technology (IJSRCSEIT)*, ISSN : 2456-3307, Volume 2, Issue 1, pp.220-224, January-February-2017.  
Journal URL : <http://ijsrcseit.com/CSEIT172151>

**Cite this article as :**

Mudappala Pranav Nair, Justin Paul, Arun Babu, Prof. Manoj Singh, "Online Question Paper and Question Bank Generator and Student Portal", *International Journal of Scientific Research in Computer Science, Engineering and Information Technology (IJSRCSEIT)*, ISSN : 2456-3307, Volume 6, Issue 3, pp.258-261, May-June-2020. Available at doi : <https://doi.org/10.32628/CSEIT206357>  
Journal URL : <http://ijsrcseit.com/CSEIT206357>