

Design and Development of Optimization Agent in Cross Layered Framework

Lokesh S¹, Jayasri B S²

¹Associate Professor, Department of Computer Science & Engineering, The National Institute of Engineering, Mysuru, India, Affiliated to Visvesvaraya Technological University, Belagavi, India

²Professor, Department of Computer Science & Engineering, The National Institute of Engineering, Mysuru, India
Affiliated to Visvesvaraya Technological University, Belagavi, India

ABSTRACT

Article Info

Volume 7, Issue 6

Page Number : 427-433

Publication Issue :

November-December-2021

Article History

Accepted : 15 Dec 2021

Published : 30 Dec 2021

A Cross Layered framework is an important concept in today's world given the abundant usage of both single-path and multi path wireless network architectures. One of the important design issues in the development of a robust framework such as this is the design of an Optimization Agent or an OA. In recent days of wireless and wired ad-hoc networks, cross-layer design was brought about a few years back to explore attached optimization at different layers. In order to describe solutions in cross-layered design, the Open System Intercommunications model was employed. However, it is clear that no voice and reference mechanism exists to aid optimization, which could effectively halt effective adaptability and deployment of cross-layered solutions. In this study, we suggest some hypotheses regarding how to model and create cross-layer solutions using the OSI layered method. We use the aforementioned method to analyse and simulate a particular type of cross-layered solution, namely energy-aware routing protocols. We use a layered approach to examine two proposals that are accessible in the literature. The applied strategy leads to the creation of an energy-aware, one-of-a-kind solution that outperforms prior versions and provides interesting and clear insights into the function that each layer plays in the overall optimization process. The network throughput, utilization, and reliability have all increased practically rapidly in the last few years. With the emergence of broadband wireless and wired cellular networks, as well as mobile adhoc networks (MANETs) and improved computational capacity, a new generation of apps, especially real-time multimedia applications, has emerged. Delivering real-time multimedia traffic across a sophisticated network like the Internet could be a particularly difficult undertaking, as these applications have stringent bandwidth and other quality-of-service (QoS) requirements.

Keywords : Cross-layer design, multi hop wireless networks, Wireless sensor networks (WSNs), cross-layer optimization, BitRate Error (BER), Optimization Agent (OA), MANETs

I. INTRODUCTION

Cross-layer design and optimization may be a novel technique that has become commonplace in recent years and enhances network performance in both wired and wireless networks. The primary concept behind cross-layer design is to optimise data control and exchange across two or more layers in order to achieve considerable performance gains by leveraging interactions between different protocol layers.

In this research, we offer a cross-layer design and optimization framework, as well as the idea of using an optimization agent to provide data interchange and control between various protocol layers in wireless sensor networks to improve performance.

The approach is to investigate the effects of the wireless channel on the physical layer performance of a small- scale wireless sensor network (WSN) in order to get insights that will be used to design and build the optimization agent within the proposed cross-layer framework.

For a group of networked wireless sensors, performance measurements were taken to examine the effects of interference and transmission range. The development of mobile ad-hoc wireless networks (MANETs) is inspired by a wide range of enticing applications that occur in dynamic circumstances where the construction of a communication infrastructure would be difficult to achieve using a different type of network.

Many of these difficult application cases impose significant network design constraints. In general, network nodes must be small, adaptable to a wide range of environments (e.g. body networks), and deployable in large numbers (i.e. dense networks); cheap, to ensure dense network deployment is cost-effective; battery-powered, to ensure autonomy and freedom of movement while simultaneously forcing the energy consumption issue to become the most important concern in order to maximise efficiency.

Communication resources may be limited as a result of these differences. Low bit rates, in particular, must be used to keep the transceiver simple while maintaining the specified bit error rate (BER). Furthermore, as the number of active nodes in the network grows, the supply of the channel diminishes.

A high number of nodes, on the other hand, promotes high connection among them. High connectivity is typically used to reduce energy by employing a multi-hop strategy, as well as to increase dependability by utilising redundancy in data collecting and message delivery.

The requirement of self-configuring, maintaining, and adapting the network to achieve the desired performance drives communication protocol design in this environment. The introduction of new functions that make efficient use of available resources makes it necessary to advance the way networks are designed. Traditionally, networks have been created using the OSI model [3], in which nodes are logically split into layers and placed in an extremely stackable manner.

Interaction between adjacent layers is enabled by defining interfaces between them. The network design is broken into an extremely large number of discrete and easier design activities once each interface has been correctly described by exposing services but hiding their implementation.

Cross-layer design could be a new way to build and operate networks, claiming a greater level of interaction between layers to develop solutions that adapt to changing conditions and application requirements[2]. The goal is to improve performance in a resource-constrained environment.

Despite the extensive literature on cross-layer optimization methods, a good definition of this methodology is still lacking. Furthermore, the functional description of cross-layer solutions is done in an unstructured way, despite the fact that the need for a reference model has been recognised in.

We analyze this with the following approach:

We develop a correct API for each layer to facilitate cross-layer interaction and we locate various elements of the analysed algorithms within the reference layers.

Our strategy is based on two main points:

- 1) It demonstrates that the OSI model's inapplicability to cross-layer design must be properly justified before claiming the need for a replacement reference model.
- 2) We overcome some limitations by creating a completely unique routing algorithm by identifying the role of each layer within the description of the two routing algorithms.

Our proposal runs for the identical goal but gives a more robust performance because of an improved cross-layer interaction. In traditional communication networks, the Open Systems Interconnection (OSI) layered architecture has been widely adopted and has

served many communications systems well within the past; however, evolving wireless networks of today are seriously challenging this design philosophy.

The layered architecture defines a stack of protocol levels, each of which functions inside its own well-defined function and boundary, allowing modifications to the underlying technology at each layer to be made without requiring changes to the overall system design. This technique has been successful in providing flexibility, transparency, and standardisation in landline networks, but it may not be appropriate for wireless networks.

Although wireless networks such as cellular networks, wireless local area networks (WLANs), mobile ad hoc networks (MANETs), and wireless sensor networks (WSNs) differ significantly in terms of their applications and architecture, one common theme that runs through all of them is the use of the wireless channel for communication.

The wireless channel, unlike wire line networks, has various distinct properties that must be taken into account while developing wireless networks [1]. As a result, we now understand the significance of an agent-based optimization system, or an optimization agent within multi-layered frameworks. In the next section, we'll look at two different designs for agent-based systems that are currently available. Later, with the help of a scenario, we'll go over a specific technique to cross-layered optimization utilising an optimization-agent.

II. ARCHITECTURES FOR AGENT- BASED SYSTEMS

A. Based on an AI Approach :-

Agent designs of many types are induced and used, with the focus on agents to decouple actions. Symbolic, reactive, and hybrid mixes of the two could be used to describe such designs. A site level layer

plus a cooperation and control layer, for example, make up the big symbolic, deliberative architecture. This design encourages declarative knowledge-based local and group control, decision-making, and execution. Building a hierarchy of tasks ranging from primitive to complicated, with the former taking precedence over the latter, supports the category of reactive architectures.

They rule out centralised symbolic reasoning in particular. Brooks' well-known subsumption architecture is one such example. With the apparent meaning, the remaining class of architectures is called as Hybrid. Ferguson and Muller are two prominent instances. The three layers in Ferguson's example are reactive, planning, and modelling. Within the spirit of reactive architectures, the reactive layer is used to respond to simple needs of agents. The other two levels are thought to support an agent's various needs, such as cognitive agent sorting, action reasoning, and decision communication to the reactive layer.

The interrap design was proposed by Muller and his colleagues. This architecture (shown in Figure 1) promotes a layered approach that allows for the separation of concerns as well as systematic interaction and cooperation. Control modules (agents), a world interface, and cognition make up the architecture. Sensors, control, orders, and communication with the environment are all made easier by the world. The world-model, mental-model, and social-model layers make up the knowledge-base agent. Object-level beliefs are included in the world model.

The mental model contains information that can assist with local planning. Negotiation procedures and cooperative planning are examples of knowledge that can be used to create a social model. There are three layers to the control agent. The behavior-based layer encourages both reactive and deliberate actions. The primary responsibility of the local planning layer is to

create single-agent plans[6]. A cooperative planning layer is used to map collaborative plans in instances where local planning is ineffective. The layers of the control and cognitive content agents in the interrap architecture enable bottom-up activation and top-down execution. The behavior-based layer communicates with the world model directly. The mental and social model levels interact with the local and cooperative planning layers, respectively. Control starts at the behavior-based layer and moves up to higher levels with *pro re nata* control. To achieve their goals, the two higher control levels will rely on lower-level control and information. This architecture only provides access to the world interface through the layers below it (behavior-based and world model), preventing simultaneous direct access to sensory input from all layers (i.e., cooperative and native planning and behavior-based).

The interrap allows users to methodically develop and test agent-based systems from the perspective of designing them. This design, on the other hand, is limited in its support for agent studies. For example, there is no support for remote execution, including logical-time and real-time simulation services.

B. A Cross Layered Approach

There is currently no well-defined framework for studying cross-layer optimization since there are several combinations of optimization techniques that can be used at various layers of the protocol stack, and each combination is unique to a specific optimization goal. Because existing protocol stacks are architected and implemented in a layered manner and do not function efficiently in mobile wireless environments, a survey on the advantages of cross-layer design optimizations in wireless protocol stacks was presented in a number of papers, where they proposed the use of cross-layer feedback to enhance

the performance of mobile devices to support future heterogeneous networks.

Top-down, bottom-up, application centric, MAC centric, and integrated techniques are just a few examples of cross-layer optimization categories based on the order in which the optimizations are executed. As illustrated in Figure 1, we present a generic framework for our study of cross-layer optimization for WSNs.

The architecture consists of a proposed optimization agent (OA), which facilitates interactions between various protocol layers by serving as a core repository or database where essential information such as node positive identification, hop count, energy state, link status, and so on is temporarily stored and used as side information for other layers across the protocol stack. Information can only be shared directly across two adjacent layers in an extremely sequential manner, which differs from the layered model approach. Intra-layer interactions (between adjacent layers) and inter-layer interactions (across two or more adjacent layers) will be classified, and these interactions will be either bottom up or top down[7]. Because of the common feedback mechanism used in control systems, such as transmitting feedback information to the top protocol layers to stabilise performance, bottom up interactions are frequently discussed.

Unlike a number of proposed cross-layer approaches that optimise performance between two adjacent layers (e.g., MAC and network layers), our proposed approach extends the cross-layering process to all or any protocol layers, allowing critical information to be exchanged across the layers to fully optimise performance at each layer. [8]

To support future applications for ubiquitous wireless networking that require high QoS and reliable packet delivery in a highly dynamic environment, the OA would need to be able to adjust and adapt to changes in the environment as well as changes in performance

at each individual protocol layer (e.g. like adapting to changing network conditions or adapting to the appliance needs).

Other proposed solutions, which place a greater emphasis on optimization across one or two protocol layers and ignore the effects of changing operating environments, do not have such adaptability across all protocol layers. Our suggested framework and concept of employing the OA provides a flexible and adaptive technique for joint optimization across all protocol layers that does not require any existing protocols to be redesigned at each layer.

III. CROSS-LAYER OPTIMIZATION APPROACHES USING OA (OPTIMIZATION AGENT)

The results and insights gained from simulations of the TDL model and measurements of Micaz motes can aid in the appearance and evolution of the OA. Mobility difficulties in WSNs, for example, can cause a wireless sensor's BER performance to suffer significantly. When the OA detects a BER degradation, it can be used to trigger an increase in transmit power to counteract the effects of mobility or channel impairments due to fading.

In the absence of mobility or channel fading, it can even cut the transmit power to save energy and extend its lifetime operations. Similarly, the OA could be used to offer the feedback mechanism needed in adaptive modulation and coding approaches to improve WSN performance by adjusting transmit power, coding rate, or rate transmissions to fit a particular application. For low bandwidth applications, such as transmitting normal temperature updates from an overseas monitoring site, the information rate transmissions are configured for a very cheap rate (i.e. update only if required or when there are changes) specified, and the sensor nodes' lifetimes may even be extended.

For applications that require the next rate, such as live streaming, motion detection, and video transmission, the information rate is frequently modified to provide the network's maximum throughput[9]. The interference problem in the two.4-GHz ISM band hinders IEEE 802.15.4 networks from performing at their best, and as a result, network performance is frequently decreased due to interference.

The OA are frequently used to provide a method for measuring or updating the network's link quality and packet received rates of success by extracting key information from the physical layer specified provisions can be made to reconfigure the wireless sensors to one of the two unaffected channels (channels 25 and 26) when potential interferences are detected within its operating vicinity. However, such a strategy may necessitate a change in the present physical layer schemes for IEEE 802.15.4 modulation from DSSS to FHSS or the adoption of UWB modulation techniques.

The OA can also be used to enable QoS provisioning for different types of traffic. This could be accomplished by tagging different priority traffic with different transmit power levels; for example, high priority traffic (e.g., urgent control messages) that must be transmitted could be tagged with the highest transmit power level, whereas standard traffic with lower priority could be tagged with a lower transmit power level.

This can help ensure that essential information and different types of priority traffic are sent throughout the network when and where they are needed. As a result, the insights gained from our study can be used to design and develop the OA, and by appropriately including the performance related to the inputs from the WSNs study, it is possible to style and make a versatile and adaptive framework that can be used in any design methodology to improve and optimise

performance not only in the area of ESNs but also in other domains.

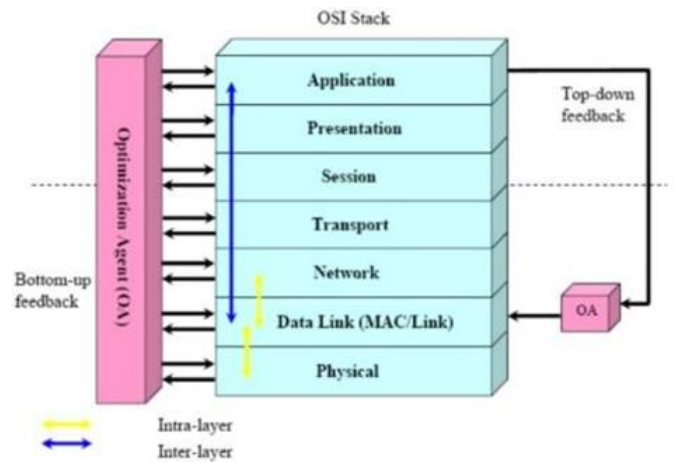

Figure 1 : Optimization Agent in Cross Layered Framework

IV. CONCLUSION AND FUTURE SCOPE

Due to the numerous benefits that cross-layer design could bring to the world, it is strongly advocated as a fresh new methodology for planning and performance optimization for wireless networks for future research. The purpose of the study was to create a design for cross-layer design and optimization. This paradigm can be utilised not only in the context of WSNs, but it can also be extended and used to other wireless network domains.

To achieve this purpose, a general cross-layer framework was presented, as well as the idea of using the OA to improve and optimise the performance of a wireless system. It would be required to understand the features and performance of each protocol layer, as well as how they interact with one another, before creating the OA and developing the cross-layer framework[10].

To provide insights and suggestions that may be used in the design and development of the OA, we examine the performance at the physical layer and how the wireless channel's implications affect the

performance of a WSN in this thesis. Because the ensuing answers are cascaded up and can affect the performance of the top levels, it's critical to understand the performance at the lower layers (i.e., wireless channel and physical layer).

The simulation was carried out in MATLAB using a tap electrical circuit (TDL) model to verify the performance of a system (e.g., a wireless sensor) under the influence of multipath fading and mobility. The results of interference and coexistence between IEEE 802.15.4 ZigBee and IEEE 802.11b WLAN networks operating inside the two.4 GHz ISM band were checked and investigated using a group of Micaz motes. Micaz motes had their transmission profiles examined and characterised after being tuned to three distinct power transmission levels.

To conclude, an Optimization Agent or OA, an essential component in a cross layered framework of network architectures, is an essential and hot topic of research and can open up a multitude of possibilities in networking.

V. REFERENCES

- [1]. KARACA, L. Ozlem, and RadosvetaSokullu. "Smart Environments and Cross-Layer Design. "Smart Wireless Sensor Networks (2012).
- [2]. D'Angelo, Massimiliano, etal. "A layered approach to modeling and design of cross-layer protocols in ad-hoc wireless networks. " 2008 IEEE Wireless Communications and Networking Conference. IEEE, 2008.
- [3]. Lee, LimT. Cross-layer design and optimization for wireless sensor networks. NAVAL POSTGRADUATE SCHOOL MONTEREYCA, 2006.
- [4]. Sarjoughian, HessamS. , BernardP. Zeigler, and Steven B. Hall. " A layered modeling and simulation architecture for agent-based system

- development. " ProceedingsoftheIEEE89. 2(2001):201-213.
- [5]. Sen, Jaydip, and ShomikBhattacharya. "A survey on cross- layer design frameworks for multimedia
- [6]. Karaca, Ozlem, and RadosvetaSokullu. "Comparative study of cross layer frameworks for wireless sensor networks. " 20091st International Conferenceon Wireless Communication, Vehicular Technology, Information Theory and Aerospace & Electronic Systems Technology. IEEE, 2009.
- [7]. Hamid, Zara, and FaisalBashirHussain. "QoS in wireless multimedia sensor networks: a layered and cross-layered approach. "Wireless Personal Communications 75. 1(2014):729-757.
- [8]. Birand , Berk, etal. "Measurements-based power control- across-layered framework. " 2013OpticalFiber Communication Conference and Exposition and the National Fiber Optic Engineers Conference (OFC/NFOEC). IEEE, 2013.
- [9]. Zheng, Shoukang, etal. "Cross-layered design of spectrum sensing and MAC for opportunistic spectrum access. " 2009 IEEE Wireless Communications and Networking Conference. IEEE, 2009.

Cite this article as :

Lokesh S, Jayasri B S, "Design and Development of Optimization Agent in Cross Layered Framework", International Journal of Scientific Research in Computer Science, Engineering and Information Technology (IJSRCSEIT), ISSN : 2456-3307, Volume 7 Issue 6, pp. 427-433, November-December 2021. Available at
doi : <https://doi.org/10.32628/CSEIT2176106>
Journal URL : <https://ijsrcseit.com/CSEIT2176106>