

Implementation of AI for Injector Quality Inspection

Tanvayee Dhawale¹, Anushka Chougule², Vaishnavi Ware³

Department of Computer Engineering, TSSM'S Padmabhooshan Vasantdada Patil Institute of Technology,
Pune, Maharashtra, India

ABSTRACT

Article Info

Volume 8, Issue 2

Page Number : 21-26

Publication Issue :

March-April-2022

Article History

Accepted: 01 March 2022

Published: 05 March 2022

A fuel injector is an integral part of the fuel injection system. It is a device that actively injects fuel into an internal-combustion (IC) engine by directly forcing the liquid fuel into the combustion chamber at an appropriate point in the piston cycle. Quality inspection of an assembled injector includes checking the injector for dents, rust, cracks, O-ring coloring and cuts, correct assembly, filter screen fitment and damage and cup inspection to name a few. Until now the injector inspection has been performed visually by a human operator. Skilled as they may be, human errors are bound to happen. What may seem as a small and insignificant defect, may cause functioning issues for the engine in the future.

This project aims to convert the physical inspection into an automated inspection process seamlessly, to reduce the operator dependency and to ensure 100% quality, by implementing an autonomous and AI driven system with computer vision that will check the injector for aesthetic defects and will give the final injector OK/NOT OK decision, while also ensuring the correct assembly. Thus, transformation of business processes by implementing new digital technologies and automation will result in opportunities for efficiency and will increase revenue.

Keywords: Automated Inspection System, Digital Camera, Image Processing, Computer Vision, Industry 4.0

I. INTRODUCTION

The purpose of the fuel injection system is to deliver fuel into the engine cylinders, while precisely controlling the injection timing, fuel atomization/mist, and other parameters. It is one of the essential parts of an engine hence the correct assembly of the injector and its quality inspection are of utmost importance.

Subparts such as injector cup, injector cup retainer, injector cup adaptor, injector clamp, and STC nut

fitment (for STC injector), all these, when assembled together, form a fuel injector. Each of these subparts has their respective part numbers engraved on their surfaces, this part number helps in correct assembly of the subparts so as to build the right combination injector. After the assembly of the injector part is done, it is engraved with an identification matrix i.e. QR code, which stores the information such as part number of the injector, date of manufacture and serial number. Further, this QR code is used to validate the correct assembly of sub parts in the inspection cycle.



Fig 1 : STC Injector



Fig 2 : Non-STC Injector

The project implementation is primarily focusing on two types of diesel fuel injectors, STC (Step Timing Control) and Non STC. The quality inspection for injector mainly consists of two types of inspections, internal assembly inspection, and aesthetic inspection. The scope of this project includes aesthetic inspection and checking if the correct subparts have been assembled for the required injector type. The aesthetic inspection includes checking the injector for clamp cracks, wrong fitment of part, identification matrix missing, o-ring damage, rust, and dents, to name a few. All these have an impact on part rework/replacement, failed part returning cost which ultimately leads to customers dissatisfaction.

The aim of this project is to implement an autonomous and AI-driven system to monitor and ensure correct assembly of injectors and final inspection of the same for any kind of quality defects. Currently, the injectors are inspected by humans/quality inspectors physically. These inspectors can check upto 40 injectors in an hour. But human errors are bound to occur, as long shifts and continuously looking at the same type of object can create fatigue, as a result of which, some anomalies might not get caught and reworked on. Implementation of this project will largely eliminate the operator dependency and help reduce human

errors to deliver higher quality products with an aim to reach 100% quality. Digitizing and automation inspection will also help in maintaining the records for all injectors that are inspected and shipped so that the data is never lost and will help the company in analyzing their progress over the years. To combat said issues and to ensure that 100% quality products are exported to the customers, this AI model is being created and implemented.

This AI driven system is a combination of 3 subsystems that work in tandem. These subsystems are: the computer vision system that collects real-time images of the system and analyses them for defects in real time. The Programmable Logic Controller(PLC) hardware helps automate the system and sends triggers to the system when the required safety checks are in place / not in place. Data analyzing system as the database to collect real-time data, analyze it and give OK/NOT OK decisions. All the necessary information is displayed for the operator on the dashboard.

II. METHODOLOGY

The AI-driven system is made of three subsystems that work in tandem, which are: the computer vision system, the PLC hardware, and data analyzing system.

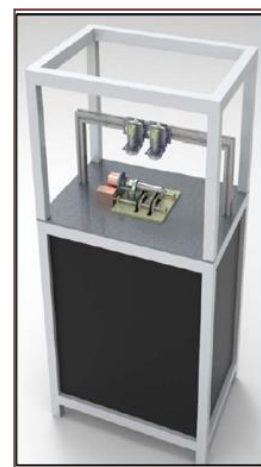

Fig 3: Chamber

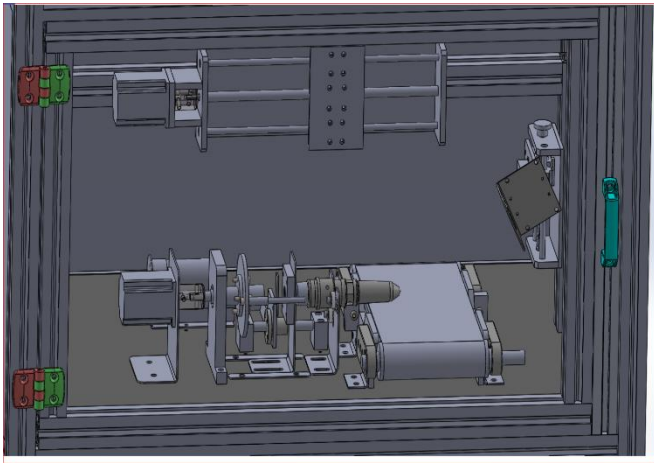

Fig 4: Inside View of Chamber

A. Hardware

The hardware design of the AI machine includes, the inspection chamber, PLC and the monitor that will show us realtime inspection and final result. The inspection chamber dimensions are:1600mm x 900mm x 700mm. Enclosure is of aluminum extrusion bar and acrylic sheet with door limit switch,magnets etc. The chamber includes two industrial/OCR cameras for capturing photos of the injector, different types of mounting fittings to accommodate STC and Non STC type of injector. Motor and conveyor assembly for rotating the injector 360 degrees during inspection cycle. The chamber is covered with dark film to avoid any external light getting in so as to not tamper with the inspection process. Two light sources are inside to provide for clean and accurate results. The PLC helps control the movement of all the hardware fittings inside the chamber such as safety checks, movement of the camera along its axial, moving the camera back to home position at the end of each cycle, give signal to the motor to start injector rotation, give signal to stop the process if any error occurs etc. The monitor/screen shows a real time dashboard with all the information of the injector that has been loaded for inspection along with the final result after the inspection cycle

B. Vision System

The objective of this vision system is to detect the injector part number by the process of QR code scanning and ensure the assembly and subassembly parts of the final injector are assembled correctly. Also the inspection of the final assembled injector does not have any defects by using the industrial camera and image processing. This entire autonomous process is independent of the operator.

C. Data Analyzing System

It acquires real time data from the vision system and aggregates it to provide real time analytics and decisions. Data acquired is real time read out of QR code for correct assembly check and identification of injector as STC/Non STC. Also real time inspection data along with selected images from the vision system.It OK/Not OK decisions after the injector inspection based on data it obtains from the vision system. This system also controls the pop up messages that appear on the monitor.Provides real time alerts to ensure that inspection is monitored and controlled. Stores all the data in the historian server for later analysis and traceability.

D. Programmable Logic Controller (PLC)

A PLC's function has three main sections: input, output and the CPU. The PLC helps control the movement of all the hardware fittings inside the chamber such as safety checks and movement of hardware inside the chamber. PLC captures data from the plant floor by monitoring inputs from machine and peripheral devices it is connected to.The input data is then processed by the CPU. The CPU then sends a signal to either of the two systems based on the data it is executing. If the safety checks/prerequisites are not in order / incomplete it signals the data analyzing system to show an alert on the

monitor so as to inform the operator about the same. If all prerequisites are complete then it signals the vision system to start its inspection cycle.

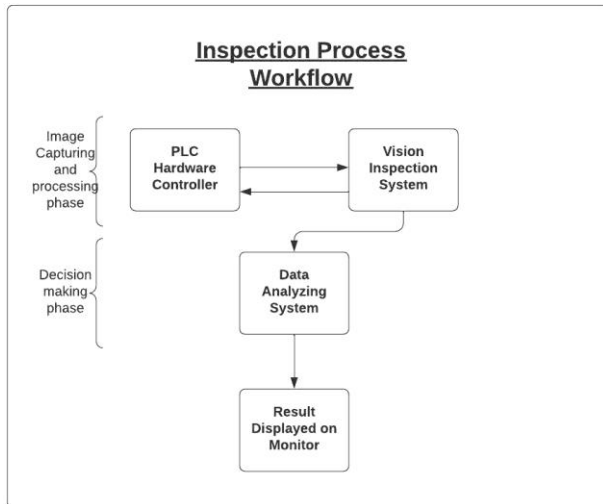

Fig 5: Workflow of Inspection Process

III.PROCEDURE

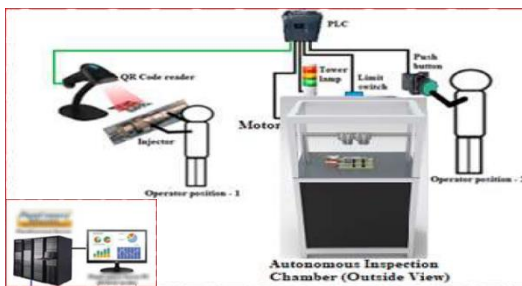

Fig 6: Procedural Flow of Inspection Process

A. Pre-requisites and Safety Checks

The most important aspect of any project is ensuring the safety of operators throughout the scope of the project. Here too, the following safety checks are to be ensured before starting the cycle:

The injector must be loaded in place properly

The chamber should not contain any foreign objects

The door should be properly closed

PLC should be in ON condition as well as the computer vision system and data analyzing system

After all of this is checked, the Operator will press the start button to start the cycle. An Emergency Stop button is provided just in case.

B. Operation

Once the safety checks and pre-requisites are completed, operator presses the 'Start' button and the inspection cycle starts. The following are the steps in which a single inspection cycle takes place:

- 1) Injector is in place and starts rotations on the conveyor belt.
- 2) Camera moves into position and starts capturing images of the rotating injector.
- 3) As soon as the images are captured, they are processed simultaneously for identification of dents, rust, cracks, line marks, damage, wrong fitment and at the same time for part number engraved on sub parts of the assembly.
- 4) The identified QR code is processed by extracting the data from it that includes the type of injector loaded: STC or Non STC, Injector identification number and part numbers of the assembled sub-parts.
- 5) Any defects identified by the computer vision software are recorded.
- 6) Once all the images are captured by the camera, the software notifies the PLC to stop the conveyor belt PLC checks if the injector is not in rotation and unlocks the door. The injector is unloaded and another injector is placed inside. The OK/NOT OK decision is taken by the software and the final result is displayed on the dashboard. Hence, another cycle starts.

C. Defect Detection on Injector Surface

Smart Cameras start capturing images once the injector starts rotating. These captured images are checked simultaneously for defects. Here arises the

question of how the computer vision system identifies defects. So, the artificial light provided inside the chamber reflects off of the injector since it's a shiny metal object. This creates a straight beam of light on the injector throughout the length of it.

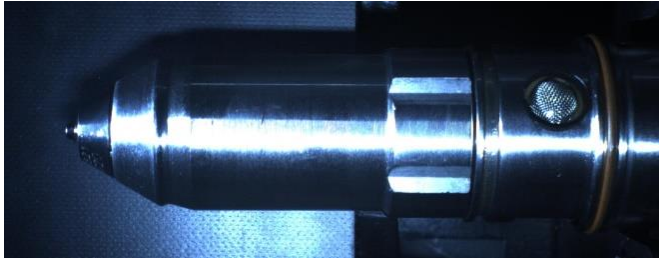

Fig 7 : Light beam on injector during inspection

This beam of light acts as a guide for the vision system. In the captured images, if the beam of light is found to be disturbed i.e. if the beam is not uniform at any point, then according to the dimensions of the disturbance, different algorithms are run to detect the type of defect.

D. Correct Assembly Checking

A QR code is present on every injector that contains the injector sub assembly details like part numbers, date of manufacture etc. This QR code is identified by the computer vision system in the images that the camera has captured. On processing the identified QR code, its details are stored in the database. The OCR camera captures images of part numbers that are engraved on the injector itself. These part numbers are crosschecked against the QR code data and again with the correct sub assembly part sequence table that is already present in the database. All of this takes place in tandem so that the inspection cycle time remains constant.



Fig 8: Outside view of chamber

IV. ADVANTAGES AND LIMITATIONS

Implementation of this project will largely eliminate the operator dependency and help reduce human errors to deliver higher quality products with an aim to reach 100% quality and in turn raising the Poka Yoke percentage. Poka Yoke is a Japanese term that means “mistake proofing”.

Engineering control will be established as robust detection can be done at the plant level. Reduction in customer complaints and aesthetic issues along with customer safeguarding, satisfaction, and functional excellence can be achieved. With digitalization we are using digital technologies to change the business model and provide a smart and automated way to conduct inspections. Digitizing and automation inspection will also help in maintaining the records for all injectors that are inspected and shipped so that the data is never lost and will help the company in analyzing their progress over the years.

Along with the advantages of this project, there are a few pressure points that have the potential to be

improved. Since all the three sub-systems are interconnected and work in tandem, if any one of those systems faces any problem, the whole process will have to be stopped until the problem is resolved. This can lead to downtime, thus reducing production. To ensure integrity of cameras and computer vision system, mastering will have to be done after a set number of cycles.

V. CONCLUSION AND FUTURE SCOPE

Implementation of this AI module will help raise the customer satisfaction index along with automation, virtual data storage, and reduced strain on the operator.

Digitization will help in the process of storing the physical database in digital format which will be useful if the user is willing to see the data of a particular injector after months or years. In accordance with Health, Safety and Environmental (HSE) regulations, Hazard Identification and Risk Assessment(HIRA) assessments are implemented to improve ergonomics. Thus transforming business processes by implementing new digital technologies, which will result in opportunities for efficiency and will increase revenue.

This project has helped in the automation of the inspection process and hence become a real-world example of the implementation of Industry 4.0 in today's businesses. Automation is helping in efficient production which decreases the cycle time while improving the quality of the product. Better data collection, process control, visualization of the manufacturing process, and analysis are the byproducts of this project. Hardware and Software of this project have worked in tandem to create this harmonious system.

VI. REFERENCES

[1] Chai Prapat, S., and S. Rujikietgumjorn. "Modeling of Positional Variability of a Fixture

Workpiece Due To Locating Errors." International Journal of Advanced Manufacturing Technology 36(2008): 724–731.

- [2] A. Karmakar, N. Dey, T. Baral, M. Chowdhury and M. Rehan, "Industrial Internet of Things: A Review," 2019 International Conference on Opto-Electronics and Applied Optics (Optronix), 2019, pp. 1-6
- [3] H. Chen, M. Hu, H. Yan and P. Yu, "Research on Industrial Internet of Things Security Architecture and Protection Strategy," 2019 International Conference on Virtual Reality and Intelligent Systems (ICVRIS), 2019, pp. 365-368
- [4] X. Li and Y. Shi, "Computer Vision Imaging Based on Artificial Intelligence," 2018 International Conference on Virtual Reality and Intelligent Systems (ICVRIS), 2018, pp. 22-25
- [5] N. B. Long, H. Tran-Dang, D. Kim, Energy-aware real-time routing for large-scale industrial internet of things, IEEE Internet of Things Journal 5 (3) (2018) 2190–2199 (June 2018)
- [6] C. Zhu, J. J. P. C. Rodrigues, V. C. M. Leung, L. Shu, L. T. Yang, Trust-based communication for the industrial internet of things, IEEE Communications Magazine 56 (2) (2018) 16–22 (Feb 2018)

Cite this article as :

Tanvayee Dhawale, Anushka Chougule, Vaishnavi Ware , "Implementation of AI for Injector Quality Inspection", International Journal of Scientific Research in Computer Science, Engineering and Information Technology (IJSRCSEIT), ISSN : 2456-3307, Volume 8 Issue 2, pp. 21-26, March-April 2022. Available at
doi : <https://doi.org/10.32628/CSEIT228148>
Journal URL : <https://ijsrcseit.com/CSEIT228148>