

# Smart Bin Enhancing Hygiene and Waste Management with IoT-Based Garbage Gas Detection

K Divya Dath<sup>1</sup>, Shaik Asiya<sup>2</sup>

M. Tech Student<sup>1</sup>, Assistant Professor<sup>2</sup>

Department of Electrical and Communication Engineering, Siddhartha Educational Academy Group of Institutions, Gollapalli, Andhra Pradesh, India

## ARTICLE INFO

## ABSTRACT

### Article History:

Accepted: 01 Aug 2023

Published: 09 Aug 2023

### Publication Issue

Volume 9, Issue 4

July-August-2023

### Page Number

292-300

This project proposes designing and implementing an intelligent waste bin management system in order to increase the efficacy of waste management and enhance environmental sustainability. To monitor and control the environmental conditions near the trash can, the system connects an Arduino Mega microcontroller to a number of sensors and communication modules. The first component of the system is two ultrasonic sensors that provide real-time data on the bin's fill level. Two sensors are placed within the bin to automatically open and close the lids: one gauges the bin's capacity at the moment, and the other regulates the lid. The system contains a MQ2 sensor to detect hazardous gases inside the bin in addition to bin level monitoring, assuring the security of waste disposal and avoiding any concerns posed by offensive odors. A MQ135 gas sensor is also installed to monitor the general air quality around the bin in order to improve waste management practises and create a healthier atmosphere. To ensure proper garbage disposal and prevent littering, an infrared (IR) sensor is utilised to check if any trash has been placed outside the trash can.

This feature promotes ethical garbage disposal practises and keeps the neighbourhood tidy. The system also includes a NodeMCU module, which makes it simpler to transfer sensor data wirelessly to a web server. Waste management authorities or other necessary professionals can remotely access this data to check bin levels, air quality, and gas concentrations. For enhanced alert capabilities, the system has a GSM module installed. The waste management staff can be alerted by SMS when bins are overflowing, gas levels are high or the air quality is poor by

using this module. This proactive strategy helps in solving potential issues promptly and enables efficient garbage collection and treatment procedures.

Last but not least, a buzzer is employed to notify users and bystanders as necessary. Data about the air quality, gas values, and bin fill level are also displayed on an LCD display. Users are provided the knowledge they need to properly dispose of waste, and environmental stewardship is promoted.

In conclusion, the proposed interface of an Arduino Mega with ultrasonic sensors, MQ2 and MQ135 gas sensors, an IR sensor, Node MCU, GSM module, buzzer and LCD produces an intelligent trash bin management system that offers monitoring, remote data access and alarms. This technology will transform waste management practices, increase environmental awareness, and make cities cleaner and healthier.

Keywords: Arduino, Gas sensor, air quality sensor, IR sensor, node MCU.

---

## I. INTRODUCTION

The environmental issues in our country have gotten worse due to the quickly growing population and the growth in rubbish. A dustbin is a receptacle used to hold recyclable, non-recyclable, and decomposable objects that have been collected from the trash. They are frequently used in homes, offices, and other places, but if they are full, nobody is there to clean them, so the waste spills out. An further factor contributing to increased pollution is the area around a trash can. Using a dustbin can cause air pollution, which can lead to the development of germs and viruses that cause fatal human diseases.

## II. RELATED WORKS

ARDUINO SMART DUSTBIN MamtaPandey[2020]

The project's major goal is to create a smart trash can that is environmentally friendly and will help to maintain a clean environment. We were motivated by the Swaach Bharat Mission. Today's technology are becoming ever more intelligent, thus in order to clean

up the environment, we are using Arduino to design a smart trashcan. The ultrasonic sensors on the dustbin are part of the smart dustbin management system, which is based on a microprocessor. If dustbins are not kept clean, the environment will become unclean and there will be more pollution, which would be bad for our health.[1].

• ARDUINO SMART DUSTBIN Rajdip Barua and Anubhab Ghosh[2014]

The project's major goal is to create an intelligent trash can that is eco-friendly and will help to maintain a clean environment. "Swaach Bharat Mission" is what motivates us. Today's technology are becoming ever more intelligent, thus in order to clean up the environment, we are using Arduino to design a smart trashcan. The ultrasonic sensors on the dustbin are part of the smart dustbin management system, which is based on a microprocessor. Dustbins that are not kept clean can lead to pollution that is bad for our health and a bad environment. With the help of an ARDUINO UNO, an ultrasonic sensor, a servo motor, and a battery jumper wire, we have created a smart

trash can for this suggested technology. once the hardware and software are connected, [2].

Things are becoming smarter as people are. While the idea of smart cities is in the mind. Waste management that is smart is necessary. Garbage that has been spilling out in and around the dustbins is a regular sight. Insects including mosquitoes, flies, bees, and driving ants can spread disease in the vicinity of poorly maintained dust bins. A dustbin's surroundings can also contribute to an increase in air pollution. Dustbin air pollution can breed germs and viruses that cause potentially fatal infections in people. The Smart Buildings, Colleges, Hospitals, and Bus Stands are the intended uses for the Smart Dustbin Accordingly, the Smart Dustbin elevates the conventional trash can by utilizing sensors and logics to make it smarter. Utilizing an ultrasonic sensor for object and distance detection, a servomotor for opening and closing the dustbin lid, a PIR sensor for determining the level of the trash can, and an LED that glows to indicate the level of the trash can's fill level, we are able to operate smart trash cans. [3].

### III.METHODOLOGY

By integrating sensors and communication modules, the suggested intelligent trash bin management system tackles the shortcomings of the conventional system. The system optimises garbage collection schedules, limiting both overflow and underutilization of collection resources by employing ultrasonic sensors to monitor the level of the bin's full. Both operational effectiveness and cost-effectiveness increase as a result. The incorporation of a MQ2 sensor enables the identification of dangerous gases inside the bin, assuring the security of waste management workers and lowering the possibility of environmental contamination. Because a MQ135 gas sensor is present, it is possible to monitor the general state of the air, allowing government agencies to take proactive steps to reduce pollution and create a healthier atmosphere.

An infrared sensor can be added to the system to detect rubbish thrown outside of the trash can, helping to prevent littering and preserve the cleanliness of the area. Both residents and visitors will benefit from a more aesthetically pleasing and clean environment thanks to this. Remote access to sensor data via a web server is made possible by the use of a Node MCU module. As a result, waste management authorities may more easily make decisions and allocate resources by remotely monitoring bin levels, air quality, and gas concentrations.

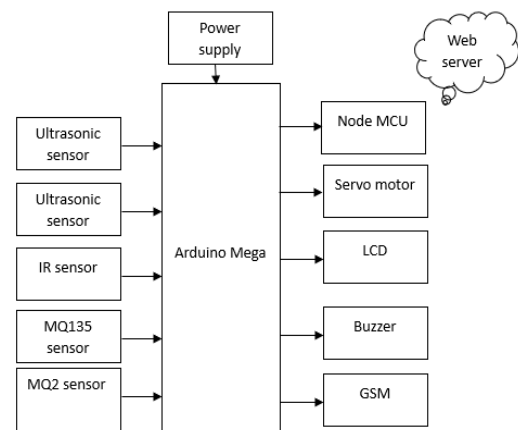

#### Arduino Mega:

Using the ATmega2560 as its foundation, the Arduino Mega 2560 is a microcontroller board. It features 16 analogue inputs, 4 hardware serial ports, a 16 MHz crystal oscillator, 54 digital input/output pins, 14 of which can be used as PWM outputs, a USB port, a power jack, an ICSP header, and a reset button. It also contains a 16 MHz crystal oscillator and a 16 MHz crystal oscillator. It comes with everything required to support the microcontroller; to get started, just plug in an AC-to-DC adapter or battery, or use it to power a computer via USB.



A computer, another board, or additional microcontrollers can be communicated with using a variety of facilities on the Mega 2560 board. Four hardware UARTs are available on the ATmega2560 for TTL (5V) serial connection. A virtual COM port is provided to software on the computer by an ATmega16U2 (ATmega 8U2 on version 1 and revision 2 boards) on the board. Windows PCs will require a .inf file, however OSX and Linux machines will automatically recognise the board as a COM port. Simple textual data can be transmitted to and received from the board using the serial monitor found in the Arduino Software (IDE). When data is transferred using the ATmega8U2/ATmega16U2 chip and USB, the RX and TX LEDs on the board will flash connection to the computer, but pins 0 and 1 cannot be used for serial communication.

Overall, the Arduino Mega is a versatile development board for beginners that can be used by both enthusiasts and experts. It is a well-liked option for quick prototyping and embedded system development due to its accessibility, price, and broad community support.

#### Ultrasonic Sensor:

An ultrasonic sensor emits ultrasonic waves into the atmosphere and detects waves that are reflected from objects. Ultrasonic sensors have various uses, including in automatic door openers, backup sensors for cars, and intrusion alarm systems. New sectors of application, such as factory automation equipment and automotive electronics, are expanding and should do so in tandem with the quick development of information processing technology. Murata has created a variety of ultrasonic sensors that are small in size but have exceptionally high performance using their specialised piezoelectric ceramic manufacturing technology, which was developed over many years. You can utilise our ultrasonic sensors more efficiently with the help of the information in this catalogue.



The HC-SR04 Ultrasonic (US) sensor, which has four pins with the labels Vcc, Trigger, Echo, and Ground, is a 4-pin module, as it is depicted above. This sensor is very well-liked and is employed in a wide range of applications where the need to measure a distance or detect objects arises. The ultrasonic transmitter and receiver are formed by two eye-like projects on the module's front. The sensor operates using a straightforward calculation from high school that  $\text{Distance} = \text{speed} \times \text{time}$ .

#### IR Sensor:

An electrical gadget that produces infrared light to sense certain features of its environment is called a sensor. An IR sensor can monitor an object's heat while also spotting movement. These kinds of sensors are referred to as passive IR sensors since they do not emit infrared radiation; instead, they merely measure it. Typically, all items emit some type of thermal radiation in the infrared range. An infrared sensor may pick up on these radiations, which are invisible to human vision. An IR LED (Light Emitting Diode) serves as the emitter, and an IR photodiode, which is sensitive to IR light of the same wavelength as that emitted by the IR LED, serves as the detector. When According on the intensity of the IR light received, the resistances and these output voltages on the photodiode fluctuate.

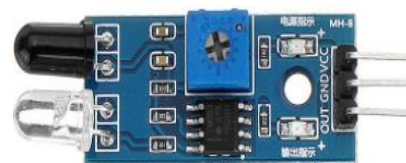

#### Buzzer:

When an electrical signal is supplied to an electromechanical buzzer, it generates an audible tone or sound. Devices with buzzers are frequently used for

a variety of purposes, including as alarms, alerts, indications, and signalling. Typically, a buzzer is made up of an armature, a coil of wire, and a speaker or diaphragm. The armature is drawn towards the wire coil when an electrical signal is delivered to it, which produces a magnetic field. The speaker or diaphragm that vibrates to generate the audible sound is often linked to the armature. Active and passive buzzer devices may be divided into two categories. An internal oscillator circuit of an active buzzer produces the sound when a voltage is supplied.

These buzzer designs are self-contained and able to generate sound without the aid of an outside signal. Active buzzers often require fewer components to function and are easier to use. An external signal is needed to activate a passive buzzer since it lacks an internal oscillator circuit. Usually, a square wave or pulse signal is used to power these kinds of buzzers. The buzzer produces sound when a voltage is supplied, which causes the speaker or diaphragm to vibrate and emit the sound. The frequency, loudness, and duration of the sound that buzzer devices produce can also vary. While some buzzers may emit a continuous tone, others may emit a pulsating or irregular sound.

LCD:

Liquid Crystal Display is referred to as LCD. Many different electronic products, such as televisions, computer displays, cellphones, calculators, and embedded systems, utilise this flat-panel display technology. LCDs provide a variety of benefits, including low power usage, a small footprint, and the capacity to show text, numbers, graphics, and pictures. There are several different varieties of LCDs, including active-matrix LCDs (TFT-LCDs), in-plane switching LCDs, and twisted nematic LCDs (TN-LCDs). The viewing angles, response times, colour reproduction, and power consumption vary depending on the kind. Thin-film transistor LCDs, often known as TFT-LCDs, are utilised extensively because of their quick reaction times and superior picture clarity.

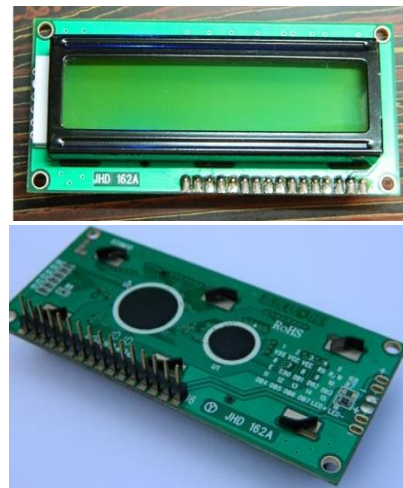

LCDs are frequently employed in embedded systems as visual output devices to provide information, user interfaces, and data readings. Using protocols like I2C or SPI, they can connect to other display controllers or microcontrollers. LCDs can frequently be programmed and controlled more easily with the help of libraries and APIs, which increases their accessibility and adaptability for a variety of applications.

MQ2:

Monitoring the gases produced is crucial in the contemporary technological environment. Monitoring of gases is particularly important for anything from household products like air conditioners to industrial safety systems and electric chimneys. A crucial component of these systems are the gas sensors. Gas sensors are tiny, resembling a nose, and respond impulsively to the gases they detect, informing the system of any changes in the concentration of molecules in the gaseous state.



Depending on the sensitivity levels, the type of gas to be sensed, the sensor's physical characteristics, and a host of other criteria, gas sensors come in a variety of specifications. This Insight focuses on a methane gas sensor that can detect other gases, including ammonia, that may be created from methane. In order for a gas to

interact with this sensor, it must first be ionised into its individual components before being adsorbed by the sensing element. Due to this adsorption, the element develops a potential difference that is transmitted as current to the processing unit through output pins.

#### MQ135:

Smoke and other dangerous gases can be detected using the MQ-135 gas sensor. It has the capacity to identify a variety of dangerous chemicals, including NH<sub>3</sub>, NO<sub>x</sub>, alcohol, benzene, smoke, and CO<sub>2</sub>. The MQ135 gas sensor is very sensitive to hazardous gases like smoke and ammonia, sulphide, and benzene steam. The MQ-135 air quality sensor and hazardous gas detection chip are both used in this module. It is simple to incorporate this module into a project that can detect dangerous gases thanks to other circuit components like the LM393 analogue comparator chip on this module. The Module offers an analogue level output (0–4V) and a digital Logic output (1 or 0), and it requires a 5V power source.



When there is no gas present, the digital logic output is LOW (0), but it becomes HIGH (1) when the environment's dangerous gas concentration reaches the threshold specified by a potentiometer on the module. Depending on the concentration of the dangerous gas in the environment, the analogue level output produces an output voltage in the range of 0 to 4V; 0V corresponds to the lowest concentration and 4V to the highest concentration..

#### GSM:

Global System for Mobile Communications, or GSM, is an industry standard for digital cellular transmission of mobile voice and data services. As a substitute for the

first-generation analogue cellular networks, it was initially developed in the 1980s.



Over 80% of mobile networks employ GSM, which runs in the 900 MHz, 1800 MHz, and 1900 MHz frequency bands. Users may take use of the technology's voice quality, security features, and data transfer capabilities, among other advantages. Over time, GSM has experienced a number of improvements, including the addition of quicker data transmission rates and better security measures. It is still a widely used mobile communication standard and has contributed significantly to the expansion of the mobile sector.

#### Power supply:

In order to power electronic equipment or circuits, a power source is a machine or a system that generates electricity. It transforms the input power from a source—like a battery or an electrical outlet—into a form appropriate for the unique needs of the devices it is powering. Consumer electronics, computers, telecommunications systems, industrial machinery, and many other types of equipment all utilize power supply.

The devices' power requirements, voltage and current ratings, efficiency, size, dependability, and safety regulations are all things to take into account when choosing a power supply. To guarantee the proper and dependable operation of the linked devices, it is crucial to select a power supply that suits the particular requirements of the application.



#### Servo motor:

An extremely precise rotating motor is known as a servo motor. This type of motor typically includes a control circuit that gives feedback on the motor shaft's present position, enabling the servo motors to rotate with extreme precision. The usage of a servo motor is necessary to rotate an object at predetermined angles or distances. A straightforward motor and servo mechanism are all that's required to operate it. The term "servo motor" refers to a motor that is powered by a DC power source, whereas the term "servo motor" refers to a motor that is powered by an AC power source. Servo motors can be divided into numerous more groups, depending on their working characteristics and gear arrangement, in addition to these basic categories. A servo motor often has a gear arrangement that makes it possible to get a very high torque servo motor in tiny, light packages. These characteristics have led to its employment in a variety of applications, including robotics, RC helicopters and planes, toy cars, and other RC vehicles.



Node MCU:

An open-source firmware and development kit called Node MCU is essential for creating your own Internet of Things (IoT) product with a few lines of Lua code. The board has a number of GPIO pins that can be used to generate PWM, I2C, SPI, and UART serial communications when connected to additional peripherals.



The interface of the module is primarily split into two sections, Firmware and Hardware, the former of which is based on the ESP8266 Wi-Fi SoC and the latter on the ESP-12 module.

The Lua programming language serves as the foundation for the firmware. A rapid scripting language that connects you with a renowned developer community, providing a basic programming environment, and being straightforward to learn.

### Advantages and Applications

#### Advantages

1. Efficiency
2. Hygiene
3. Convenience
4. Environmentally friendly
5. Smart features

#### Applications

1. Residential areas
2. Commercial buildings
3. Public spaces
4. Educational institutions
5. Healthcare facilities
6. Recreational areas
7. Industrial sites
8. Transportation hubs
9. Smart cities

## IV.RESULTS AND DISCUSSIONS



Figure :1

In this project, the integrates sensors, IoT connectivity, and transform dustbin monitoring With Arduino Mega as the core component, it enables real-time data collection and analysis. The system empowers users with actionable insights to address dustbin monitoring effectively.



Figure:2

The LCD display shows air quality readings.



Figure:3

The LCD display shows bin level



Figure:4

The LCD display shows gas readings



Figure:5

When the person detected automatically dustbin open

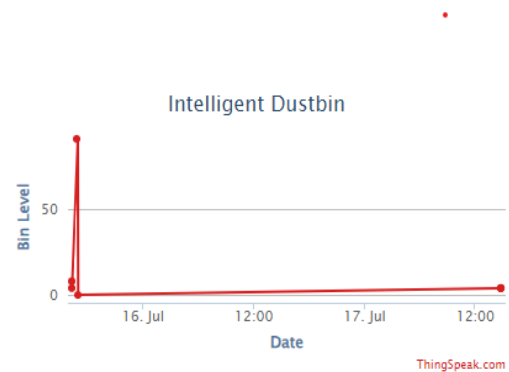

Figure:6



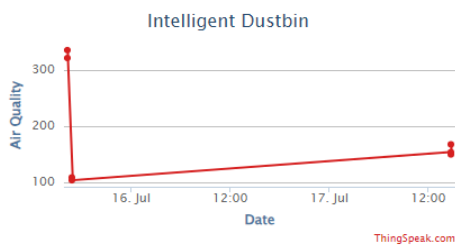

Figure:7

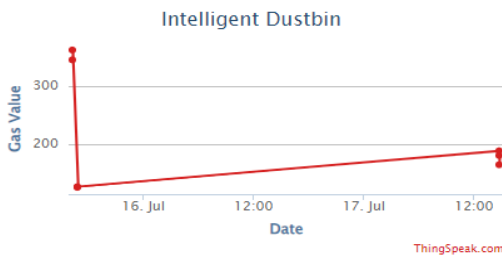

Figure:8

The sensor values are uploaded in Thingspeak server (IOT). These are the field values uploaded according to the specific sensors and measurements that are used in dustbin monitoring system. Remember to ensure that the data format and types match the requirements of the Thingspeak platform that are using.

## V. CONCLUSION

The MQ2, MQ135, Node MCU, and Ultrasonic sensor, controller, and IR sensor are all combined into this project. The introduction of an ultrasonic sensor will result in more precise readings and will enable more economical and effective rubbish collection. By putting this initiative into action, we can stop trash cans in residential areas from overflowing, preventing many diseases, and maintaining a clean environment. The user will receive the notification automatically thanks to this mechanism.

In conclusion, the IDGGD system, sometimes referred to as the SmartBin, is a ground-breaking technology that supports a hygienic environment through effective and intelligent waste management. The

SmartBin equips communities to take an active role in trash reduction and environmental conservation by utilising IoT technology and real-time gas detection. The SmartBin lays the path for a cleaner and healthier future for future generations by adhering to innovation and sustainability.

## VI. REFERENCES

- [1]. Navghane S.S., Killedar M.S., Rohokale Dr.V.M, IoT Based Smart Garbage and Waste Collection Bin, International Journal of Advanced Research in Electronics and Communication Engineering (IJARECE) 5(5) (2016).
- [2]. Sahu R.M., Akshay Godase, Pramod Shinde, Reshma Shinde Garbage and Street Light Monitoring System Using Internet of Things, International Journal Of Innovative Research In Electrical, Electronics, Instrumentation And Control Engineering 4(4) (2016).
- [3]. Tarandeep Singh, Rita Mahajan, Deepak Bagai, Smart Waste Management using Wireless Sensor Network, International Journal of Innovative Research in Computer and Communication Engineering 4(6) (2016).
- [4]. Hitendrasinh. C. Chawda, "Causes of Failure of Distribution Transformer and its Remedial Measures", Indian Journal of Applied Research, Vol.5, Issue.7, pp.606-607, July 2015.

**Cite this article as :**

Sh